



(51) International Patent Classification:

F23D 14/02 (2006.01) F23D 14/62 (2006.01)
F23D 14/08 (2006.01)

(21) International Application Number:

PCT/IB2014/003111

(22) International Filing Date:

4 December 2014 (04.12.2014)

(25) Filing Language:

English

(26) Publication Language:

English

(30) Priority Data:

61/911,582 4 December 2013 (04.12.2013) US

(71) Applicant: **KING ABDULLAH UNIVERSITY OF SCIENCE AND TECHNOLOGY** [SA/SA]; 4700 King Abdullah University of Science and Technology, Thuwal, 23955-6900 (SA).

(72) Inventors: **CHUNG, Suk Ho**; 4700 King Abdullah University of Science and Technology, Thuwal, 23955-6900 (SA). **ABDO, Markous**; 4700 King Abdullah University

of Science and Technology, Thuwal, 23955-6900 (SA). **DAWOOD, Alaa**; 4700 King Abdullah University of Science and Technology, Thuwal, 23955-6900 (SA).

(81) Designated States (unless otherwise indicated, for every kind of national protection available): AE, AG, AL, AM, AO, AT, AU, AZ, BA, BB, BG, BH, BN, BR, BW, BY, BZ, CA, CH, CL, CN, CO, CR, CU, CZ, DE, DK, DM, DO, DZ, EC, EE, EG, ES, FI, GB, GD, GE, GH, GM, GT, HN, HR, HU, ID, IL, IN, IR, IS, JP, KE, KG, KN, KP, KR, KZ, LA, LC, LK, LR, LS, LU, LY, MA, MD, ME, MG, MK, MN, MW, MX, MY, MZ, NA, NG, NI, NO, NZ, OM, PA, PE, PG, PH, PL, PT, QA, RO, RS, RU, RW, SA, SC, SD, SE, SG, SK, SL, SM, ST, SV, SY, TH, TJ, TM, TN, TR, TT, TZ, UA, UG, US, UZ, VC, VN, ZA, ZM, ZW.

(84) Designated States (unless otherwise indicated, for every kind of regional protection available): ARIPO (BW, GH, GM, KE, LR, LS, MW, MZ, NA, RW, SD, SL, ST, SZ, TZ, UG, ZM, ZW), Eurasian (AM, AZ, BY, KG, KZ, RU, TJ, TM), European (AL, AT, BE, BG, CH, CY, CZ, DE, DK, EE, ES, FI, FR, GB, GR, HR, HU, IE, IS, IT, LT, LU, LV, MC, MK, MT, NL, NO, PL, PT, RO, RS, SE, SI, SK,

[Continued on next page]

(54) Title: APPARATUSES AND METHODS FOR COMBUSTION

(57) Abstract: Combustion apparatuses (e.g., burners) and methods, such as those configured to encourage mixing of fluid and flame stability, among other things.

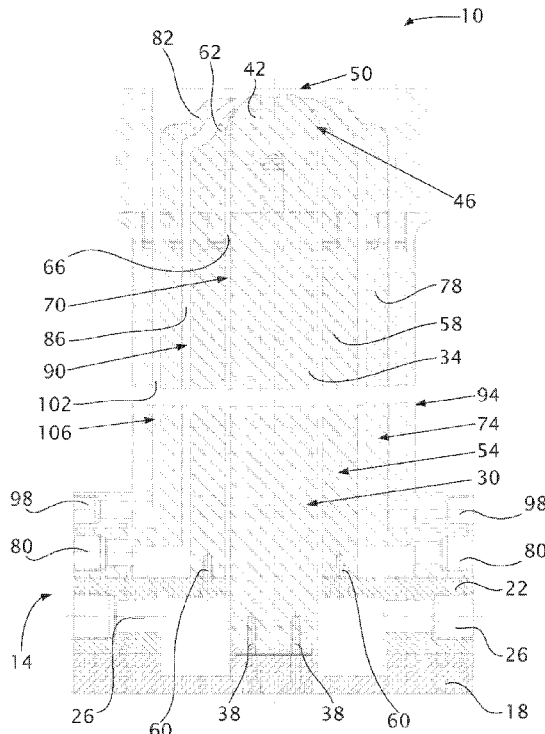

FIG. 1

WO 2015/083006 A2

SM, TR), OAPI (BF, BJ, CF, CG, CI, CM, GA, GN, GQ, GW, KM, ML, MR, NE, SN, TD, TG). **Published:**

— *without international search report and to be republished upon receipt of that report (Rule 48.2(g))*

DESCRIPTION**APPARATUSES AND METHODS FOR COMBUSTION****CROSS-REFERENCE TO RELATED APPLICATIONS**

[0001] This application claims priority to U.S. Provisional Patent Application No.
5 61/911,582, filed December 4, 2013, which is incorporated by reference in its entirety.

BACKGROUND**1. Field of the Invention**

[0002] The present invention relates generally to combustion apparatuses (e.g.,
burners) and methods, and more particularly, but not by way of limitation, to combustion
10 apparatuses and methods configured to encourage mixing of fluid and flame stability, among
other things.

2. Description of Related Art

[0003] Examples of combustion apparatuses and methods are disclosed, for example,
in Korean Reg. No. 1002257500000 and U.S. Patent No. 2,836,234.

15

SUMMARY

[0004] This disclosure includes embodiments of combustion apparatuses (e.g.,
burners) and methods configured, for example, to encourage mixing of fluid and flame
stability, among other things. The disclosed combustion apparatuses and methods can - in
part by utilizing the Coanda effect - increase flame stability, increase burner loads and burn
20 efficiencies, increase turbulent fluid flow after fluid exits the apparatuses and strengthen the
degree of strain rate (e.g., by maximizing the velocity gradient and jet impingement of fluid
moving through the apparatuses), increase blow-off velocity, increase mixing of fluid that
exits the apparatuses, and decrease flashback (e.g., by reducing quenching distance of
reactants while in contact with the apparatuses). Further, the present apparatuses and
25 methods permit variation of parameters, such as temperature, flame height, fluid flow rate,
and types and compositions of fluid moving through the apparatuses, among other things.

[0005] Some embodiments of the present combustion apparatuses comprise a center
member having a longitudinal axis and comprising: a body, where at least a portion of the
body is substantially cylindrical; and a tip integral with the body, where at least a portion of

the tip is substantially hemispherical; a first outer member comprising: a body; a tip integral with the body; and a bore concentric with the longitudinal axis of the center member; where the first outer member is positioned such that a first channel is defined between the first outer member and the center member; and a second outer member comprising: a body; a tip integral with the body; and a bore concentric with the longitudinal axis of the center member; where the second outer member is positioned such that a second channel is defined between the second outer member and the first outer member; where the apparatus is configured to: permit fluid to move through the first channel and out of the tip of the first outer member; and permit fluid to move through the second channel and out of the tip of the second outer member. In some embodiments, at least a portion of the tip of the first outer member and at least a portion of the tip of the second outer member each extends toward the tip of the center member. In some embodiments, the center member is 250 to 320 millimeters in length. In some embodiments, the center member is 285 millimeters in length. In some embodiments, the center member comprises a diameter of 25 to 75 millimeters. In some embodiments, the center member comprises a diameter of 50 millimeters. In some embodiments, the first outer member is 230 to 300 millimeters in length. In some embodiments, the first outer member is 265 millimeters in length. In some embodiments, the bore of the first outer member comprises a diameter of 20 to 80 millimeters. In some embodiments, the bore of the first outer member comprises a diameter of 56 millimeters. In some embodiments, the first outer member comprises a diameter of 70 to 120 millimeters. In some embodiments, the first outer member comprises a diameter of 96 millimeters. In some embodiments, the second outer member is 190 to 260 millimeters in length. In some embodiments, the second outer member is 228 millimeters in length. In some embodiments, the bore of the second outer member comprises a diameter of 70 to 140 millimeters. In some embodiments, the bore of the second outer member comprises a diameter of 106 millimeters. In some embodiments, the second outer member comprises a diameter of 110 to 160 millimeters. In some embodiments, the second outer member comprises a diameter of 131.5 millimeters. In some embodiments, at least a portion of the first channel comprises a width of 3 millimeters. In some embodiments, at least a portion of the second channel comprises a width of 5 millimeters. In some embodiments, the center member is adjustable with respect to the first outer member and the second outer member such that at least a portion of the first channel and the second channel can change in width. In some embodiments, the first outer member is adjustable with respect to the center member such that at least a portion of the first channel can change in width. In some embodiments, the second outer member is adjustable with respect to the center member

such that at least a portion of the second channel can change in width. In some embodiments, the apparatus further comprises four inlets in fluid communication with the first channel through which fluid can enter the first channel; and four inlets in fluid communication with the second channel through which fluid can enter the second channel. In some embodiments, the tip of the center member has a first end and a second end, and the second end of the tip is substantially concave. In some embodiments, the apparatus further comprises a swirling vane coupled to the center member and extending at least partially into the first channel such that fluid moving through the first channel is disturbed. In some embodiments, the apparatus further comprises a swirling vane coupled to the center member and extending at least partially into the second channel such that fluid moving through the first channel and the second channel is disturbed. In some embodiments, the apparatus further comprises a swirling vane coupled to the center member, where if the center member comprises a bore concentric with the longitudinal axis of the center member and extending through the body and the tip of the center member, fluid moving through the bore of the center member is disturbed. In some embodiments, the first outer member is configured such that fluid can be introduced into the first channel substantially perpendicular to the first channel. In some embodiments, the second outer member is configured such that fluid can be introduced into the second channel substantially perpendicular to the second channel. In some embodiments, the apparatus further comprises a spark plug coupled to the center member.

[0006] Some embodiments of the present combustion apparatuses comprise a center member having a longitudinal axis and comprising: a body, where at least a portion of the body is substantially cylindrical; a tip integral with the body, where at least a portion of the tip is substantially hemispherical; and a bore concentric with the longitudinal axis of the center member, the bore extending through the body and the tip; and a first outer member comprising: a body; a tip integral with the body; and a bore concentric with the longitudinal axis of the center member; where the first outer member is positioned such that a first channel is defined between the first outer member and the center member, a second outer member comprising: a body; a tip integral with the body; and a bore concentric with the longitudinal axis of the center member; where the second outer member is positioned such that a second channel is defined between the second outer member and the first outer member; where the apparatus is configured to: permit fluid to move through the bore of the center member and out of the tip of the center member; permit fluid to move through the first channel and out of the tip of the first outer member; and permit fluid to move through the second channel and out of the tip of the second outer member. In some embodiments, at least a portion of the tip

of the first outer member and at least a portion of the tip of the second outer member each extends toward the tip of the center member. In some embodiments, the center member is 250 to 320 millimeters in length. In some embodiments, the center member is 285 millimeters in length. In some embodiments, the center member comprises a diameter of 25 to 75 millimeters. In some embodiments, the center member comprises a diameter of 50 millimeters. In some embodiments, the first outer member is 230 to 300 millimeters in length. In some embodiments, the first outer member is 265 millimeters in length. In some embodiments, the bore of the first outer member comprises a diameter of 20 to 80 millimeters. In some embodiments, the bore of the first outer member comprises a diameter of 56 millimeters. In some embodiments, the first outer member comprises a diameter of 70 to 120 millimeters. In some embodiments, the first outer member comprises a diameter of 96 millimeters. In some embodiments, the second outer member is 190 to 260 millimeters in length. In some embodiments, the second outer member is 228 millimeters in length. In some embodiments, the bore of the second outer member comprises a diameter of 70 to 140 millimeters. In some embodiments, the bore of the second outer member comprises a diameter of 106 millimeters. In some embodiments, the second outer member comprises a diameter of 110 to 160 millimeters. In some embodiments, the second outer member comprises a diameter of 131.5 millimeters. In some embodiments, at least a portion of the first channel comprises a width of 3 millimeters. In some embodiments, at least a portion of the second channel comprises a width of 5 millimeters. In some embodiments, the center member is adjustable with respect to the first outer member and the second outer member such that at least a portion of the first channel and the second channel can change in width. In some embodiments, the first outer member is adjustable with respect to the center member such that at least a portion of the first channel can change in width. In some embodiments, the second outer member is adjustable with respect to the center member such that at least a portion of the second channel can change in width. In some embodiments, the apparatus further comprises four inlets in fluid communication with the first channel through which fluid can enter the first channel; and four inlets in fluid communication with the second channel through which fluid can enter the second channel. In some embodiments, the tip of the center member has a first end and a second end, and the second end of the tip is substantially concave. In some embodiments, the apparatus further comprises a swirling vane coupled to the center member and extending at least partially into the first channel such that fluid moving through the first channel is disturbed. In some embodiments, the apparatus further comprises a swirling vane coupled to the center member and extending at least

partially into the second channel such that fluid moving through the first channel and the second channel is disturbed. In some embodiments, the apparatus further comprises a swirling vane coupled to the center member such that fluid moving through the bore of the center member is disturbed. In some embodiments, the first outer member is configured such that fluid can be introduced into the first channel substantially perpendicular to the first channel. In some embodiments, the second outer member is configured such that fluid can be introduced into the second channel substantially perpendicular to the second channel. In some embodiments, the apparatus further comprises a spark plug coupled to the center member.

10 **[0007]** Some embodiments of the present combustion apparatuses comprise a base; and a center member having a longitudinal axis and comprising: a body coupled to the base, where at least a portion of the body is substantially cylindrical; and a tip integral with the body, where at least a portion of the tip is substantially hemispherical; a first outer member comprising: a body; a tip integral with the body, where at least a portion of the tip of the center member is farther from the base than the tip of the first outer member; and a bore concentric with the longitudinal axis of the center member; where the first outer member is positioned such that a first channel is defined between the first outer member and the center member; and a second outer member comprising: a body; a tip integral with the body, where at least a portion of the tip of the center member is farther from the base than the tip of the second outer member; and a bore concentric with the longitudinal axis of the center member; where the second outer member is positioned such that a second channel is defined between the second outer member and the first outer member; where the apparatus is configured to: permit fluid to move through the first channel and out of the tip of the first outer member; and permit fluid to move through the second channel and out of the tip of the second outer member. In some embodiments, at least a portion of the tip of the first outer member and at least a portion of the tip of the second outer member each extends toward the tip of the center member. In some embodiments, the center member is 250 to 320 millimeters in length. In some embodiments, the center member is 285 millimeters in length. In some embodiments, the center member comprises a diameter of 25 to 75 millimeters. In some embodiments, the center member comprises a diameter of 50 millimeters. In some embodiments, the first outer member is 230 to 300 millimeters in length. In some embodiments, the first outer member is 265 millimeters in length. In some embodiments, the bore of the first outer member comprises a diameter of 20 to 80 millimeters. In some embodiments, the bore of the first outer member comprises a diameter of 56 millimeters. In some embodiments, the first outer

member comprises a diameter of 70 to 120 millimeters. In some embodiments, the first outer member comprises a diameter of 96 millimeters. In some embodiments, the second outer member is 190 to 260 millimeters in length. In some embodiments, the second outer member is 228 millimeters in length. In some embodiments, the bore of the second outer member comprises a diameter of 70 to 140 millimeters. In some embodiments, the bore of the second outer member comprises a diameter of 106 millimeters. In some embodiments, the second outer member comprises a diameter of 110 to 160 millimeters. In some embodiments, the second outer member comprises a diameter of 131.5 millimeters. In some embodiments, at least a portion of the first channel comprises a width of 3 millimeters. In some embodiments, at least a portion of the second channel comprises a width of 5 millimeters. In some embodiments, the center member is adjustable with respect to the first outer member and the second outer member such that at least a portion of the first channel and the second channel can change in width. In some embodiments, the first outer member is adjustable with respect to the center member such that at least a portion of the first channel can change in width. In some embodiments, the second outer member is adjustable with respect to the center member such that at least a portion of the second channel can change in width. In some embodiments, the apparatus further comprises four inlets in fluid communication with the first channel through which fluid can enter the first channel; and four inlets in fluid communication with the second channel through which fluid can enter the second channel. In some embodiments, the tip of the center member has a first end and a second end, and the second end of the tip is substantially concave. In some embodiments, the apparatus further comprises a swirling vane coupled to the center member and extending at least partially into the first channel such that fluid moving through the first channel is disturbed. In some embodiments, the apparatus further comprises a swirling vane coupled to the center member and extending at least partially into the second channel such that fluid moving through the first channel and the second channel is disturbed. In some embodiments, the apparatus further comprises a swirling vane coupled to the center member, where if the center member comprises a bore concentric with the longitudinal axis of the center member and extending through the body and the tip of the center member, fluid moving through the bore of the center member is disturbed. In some embodiments, the first outer member is configured such that fluid can be introduced into the first channel substantially perpendicular to the first channel. In some embodiments, the second outer member is configured such that fluid can be introduced into the second channel substantially perpendicular to the second channel. In some embodiments, the apparatus further comprises a spark plug coupled to the center member.

[0008] Some embodiments of the present methods comprise introducing a first fluid into a first channel defined by: a center member having a tip, where at least a portion of the tip is substantially hemispherical; and a first outer member; introducing a second fluid into a second channel defined by the first outer member and a second outer member; permitting the first fluid and the second fluid to flow over the tip of the center member and to mix; and igniting the mixture of the first fluid and the second fluid. In some embodiments, the method further comprises introducing the first fluid into the first channel substantially perpendicular to the first channel. In some embodiments, the method further comprises introducing the second fluid into the second channel substantially perpendicular to the second channel. In some embodiments, the method further comprises adjusting the center member with respect to the first outer member and the second outer member such that at least a portion of the first channel and the second channel changes in width. In some embodiments, the method further comprises adjusting the first outer member with respect to the center member such that at least a portion of the first channel changes in width. In some embodiments, a width of the at least a portion of the first channel is similar to a quenching distance. In some embodiments, the method further comprises adjusting the second outer member with respect to the center member such that at least a portion of the second channel changes in width. In some embodiments, a width of the at least a portion of the second channel is similar to a quenching distance. In some embodiments, a spark plug is coupled to the center member, and the method further comprises igniting the mixture of the first fluid and the second fluid with the spark plug. In some embodiments, the first fluid comprises fuel and the second fluid comprises air. In some embodiments, the first fluid comprises air and the second fluid comprises fuel. In some embodiments, the first fluid comprises fuel and the second fluid comprises an oxidizer. In some embodiments, the first fluid comprises an oxidizer and the second fluid comprises fuel. In some embodiments, the first fluid comprises a mixture of air and fuel and the second fluid comprises a mixture of fuel and air. In some embodiments, the first fluid comprises a mixture of oxidizer and fuel and the second fluid comprises a mixture of fuel and oxidizer. In some embodiments, the first fluid comprises a lean pre-mixture and the second fluid comprises a rich pre-mixture. In some embodiments, the lean pre-mixture and the rich pre-mixture are inflammable. In some embodiments, the first fluid comprises a rich pre-mixture and the second fluid comprises a lean pre-mixture. In some embodiments, the lean pre-mixture and the rich pre-mixture are inflammable.

[0009] Some embodiments of the present methods comprise introducing a first fluid into a first channel defined by a center member and a first outer member; introducing a

second fluid into a second channel defined by the first outer member and a second outer member; introducing a third fluid through a bore of the center member, where the center member has a longitudinal axis and comprises: a body, where at least a portion of the body is substantially cylindrical; and a tip integral with the body, where at least a portion of the tip is substantially hemispherical; where the bore of the center member is concentric with the longitudinal axis of the center member and extends through the body and the tip; permitting the first fluid and the second fluid to flow over the tip of the center member and to mix with the third fluid; and igniting the mixture of the first fluid, the second fluid, and the third fluid. In some embodiments, the method further comprises introducing the first fluid into the first channel substantially perpendicular to the first channel. In some embodiments, the method further comprises introducing the second fluid into the second channel substantially perpendicular to the second channel. In some embodiments, the method further comprises adjusting the center member with respect to the first outer member and the second outer member such that at least a portion of the first channel and the second channel changes in width. In some embodiments, the method further comprises adjusting the first outer member with respect to the center member such that at least a portion of the first channel changes in width. In some embodiments, a width of the at least a portion of the second channel is similar to a quenching distance. In some embodiments, the method further comprises adjusting the second outer member with respect to the center member such that at least a portion of the second channel changes in width. In some embodiments, a width of the at least a portion of the first channel is similar to a quenching distance. In some embodiments, a spark plug is coupled to the center member, and the method further comprises igniting the mixture of the first fluid, the second fluid, and the third fluid with the spark plug. In some embodiments, the first fluid comprises fuel and the second fluid comprises air. In some embodiments, the first fluid comprises air and the second fluid comprises fuel. In some embodiments, the first fluid comprises fuel and the second fluid comprises an oxidizer. In some embodiments, the first fluid comprises an oxidizer and the second fluid comprises fuel. In some embodiments, the first fluid comprises a mixture of air and fuel and the second fluid comprises a mixture of fuel and air. In some embodiments, the first fluid comprises a mixture of oxidizer and fuel and the second fluid comprises a mixture of fuel and oxidizer. In some embodiments, the first fluid comprises a lean pre-mixture and the second fluid comprises a rich pre-mixture. In some embodiments, the lean pre-mixture and the rich pre-mixture are inflammable. In some embodiments, the first fluid comprises a rich pre-mixture and the second fluid comprises a lean pre-mixture. In some embodiments, the lean pre-

mixture and the rich pre-mixture are inflammable. In some embodiments, the first fluid comprises fuel, the second fluid comprises air, and the third fluid comprises fuel. In some embodiments, the first fluid comprises air, the second fluid comprises fuel, and the third fluid comprises fuel.

5 [0010] The term “coupled” is defined as connected, although not necessarily directly, and not necessarily mechanically. Two items are “couplable” if they can be coupled to each other. Unless the context explicitly requires otherwise, items that are couplable are also decouplable, and vice-versa. One non-limiting way in which a first structure is couplable to a second structure is for the first structure to be configured to be coupled (or configured to be
10 couplable) to the second structure. The terms “a” and “an” are defined as one or more unless this disclosure explicitly requires otherwise. The term “substantially” is defined as largely but not necessarily wholly what is specified (and includes what is specified; e.g., substantially 90 degrees includes 90 degrees and substantially parallel includes parallel), as understood by a person of ordinary skill in the art. In any disclosed embodiment, the terms “substantially,”
15 “approximately,” and “about” may be substituted with “within [a percentage] of” what is specified, where the percentage includes 0.1, 1, 5, and 10 percent.

[0011] The terms “comprise” (and any form of comprise, such as “comprises” and “comprising”), “have” (and any form of have, such as “has” and “having”), “include” (and any form of include, such as “includes” and “including”) and “contain” (and any form of
20 contain, such as “contains” and “containing”) are open-ended linking verbs. As a result, an apparatus, or a component of an apparatus that “comprises,” “has,” “includes” or “contains” one or more elements or features possesses those one or more elements or features, but is not limited to possessing only those elements or features. Likewise, a method that “comprises,”
25 “has,” “includes” or “contains” one or more steps possesses those one or more steps, but is not limited to possessing only those one or more steps. Additionally, terms such as “first” and “second” are used only to differentiate structures or features, and not to limit the different structures or features to a particular order.

[0012] Any embodiment of any of the present combustion apparatuses and methods can consist of or consist essentially of – rather than comprise/include/contain/have – any of
30 the described elements and/or features. Thus, in any of the claims, the term “consisting of” or “consisting essentially of” can be substituted for any of the open-ended linking verbs recited above, in order to change the scope of a given claim from what it would otherwise be using the open-ended linking verb.

[0013] The feature or features of one embodiment may be applied to other embodiments, even though not described or illustrated, unless expressly prohibited by this disclosure or the nature of the embodiments.

[0014] Details associated with the embodiments described above and others are presented below.

BRIEF DESCRIPTION OF THE DRAWINGS

[0015] The following drawings illustrate by way of example and not limitation. For the sake of brevity and clarity, every feature of a given structure is not always labeled in every figure in which that structure appears. Identical reference numbers do not necessarily indicate an identical structure. Rather, the same reference number may be used to indicate a similar feature or a feature with similar functionality, as may non-identical reference numbers. At least some of the figures depict graphical symbols or representations that will be understood by those of ordinary skill in the art. The embodiments of the present combustion apparatuses and their components shown in the figures are drawn to scale.

[0016] **FIG. 1** depicts a side, cross-sectional view of an embodiment of a combustion apparatus comprising a base, a center member, a first outer member positioned such that a first channel is defined between the first outer member and the center member, and a second outer member positioned such that a second channel is defined between the second outer member and the first outer member.

[0017] **FIG. 2** depicts a top view of the combustion apparatus of FIG. 1.

[0018] **FIGS. 3A** depicts an embodiment of a portion of a combustion apparatus comprising a center member, a first outer member positioned such that a first channel is defined between the first outer member and the center member, and a second outer member positioned such that a second channel is defined between the second outer member and the first outer member.

[0019] **FIG. 3B** depicts another embodiment of a portion of a combustion apparatus comprising a center member, a first outer member positioned such that a first channel is defined between the first outer member and the center member, and a second outer member positioned such that a second channel is defined between the second outer member and the first outer member.

[0020] **FIG. 4A** depicts an embodiment of a portion of a center member of a combustion apparatus, where the tip of the center member has a first end and a second end, and the second end of the tip is substantially concave.

[0021] FIG. 4B depicts another embodiment of a portion of a center member of a combustion apparatus.

[0022] FIG. 4C depicts another embodiment of a portion of a center member of a combustion apparatus, where the center member has a bore.

5 [0023] FIG. 4D depicts another embodiment of a portion of a center member of a combustion apparatus, where the combustion apparatus comprises a swirling vane coupled to the center member.

[0024] FIG. 4E depicts another embodiment of a portion of a center member of a combustion apparatus, where the combustion apparatus comprises a spark plug coupled to the
10 center member.

[0025] FIG. 5 depicts an embodiment of a portion of a first outer member of a combustion apparatus.

[0026] FIG. 6 depicts an embodiment of a portion of a second outer member of a combustion apparatus.

15 [0027] FIG. 7 depicts an example of the Coanda effect.

[0028] FIG. 8 depicts an example of fluid flow over a portion of one embodiment of the present combustion apparatuses.

[0029] FIG. 9 depicts experimental results from the use of one embodiment of the present combustion apparatuses.

20 DESCRIPTION OF ILLUSTRATIVE EMBODIMENTS

[0030] Referring now to the drawings, and more particularly to FIGS. 1-2, there is shown combustion apparatus 10 comprising base 14. Base 14 can comprise any number of members configured to, for example, stabilize combustion apparatus 10, provide fluid to combustion apparatus 10, and the like. For example, in the embodiment shown in FIG. 1,
25 base 14 comprises lower latitudinal member 18 coupled to upper longitudinal members 22. Lower latitudinal member 18 can be coupled to upper latitudinal member 22 in any suitable way (e.g., bolts, nails, adhesives, welds, and the like). In other embodiments, lower latitudinal member 18 and upper latitudinal member 22 can be integral (e.g., formed of the same piece of material). In the embodiment shown in FIG. 1, apparatus 10 comprises inlets
30 26 extending through base 14 (e.g., lower latitudinal member 18 coupled to upper longitudinal members 22). Apparatus 10 can comprise any number of inlets 26, such as, for example, one, two, three, four, five, six, or more inlets 26. Inlets 26 are in fluid communication with apparatus 10 such that fluid can enter apparatus 10 through inlets 26.

[0031] In the embodiment shown, combustion apparatus 10 further comprises center member 30 having a longitudinal axis. Center member 30 includes body 34 coupled to base 14 (e.g., lower latitudinal member 18). In the embodiment shown, body 34 of center member 30 is coupled to base 14 (e.g., lower latitudinal member 18) by screws 38 (e.g., six screws 38, as depicted in FIG. 2). However, in some embodiments, body 34 of center member 30 can be coupled to base 14 (e.g., lower latitudinal member 18) in any suitable way (e.g., bolts, nails, adhesives, welds, and the like); and in other embodiments, base 14 (e.g., lower latitudinal member 18) and center member 30 can be integral (e.g., formed of the same piece of material). In the embodiment shown, body 34 of center member 30 is substantially cylindrical. Center member 30 also includes tip 42, which is integral with body 34. In the embodiment shown, tip 42 of center member 30 is substantially hemispherical. Tip 42 comprises first end 46, which is proximal to base 14 and integral with body 34, and second end 50, which is distal to base 14. In some embodiments, center member 30 comprises a length of 250 to 320 millimeters (e.g., 285 millimeters); and in other embodiments, a length of center member 30 can be less than 250 millimeters (e.g., 245, 240, 235 millimeters, or less) or more than 320 millimeters (e.g., 325, 330, 335 millimeters, or more). In some embodiments, body 34 of center member 30 comprises a diameter of 25 to 75 millimeters (e.g., 50 millimeters); and in other embodiments, a diameter of body 34 of center member 30 can be less than 25 millimeters (e.g., 20, 15, 10 millimeters, or less) or more than 75 millimeters (e.g., 80, 85, 90 millimeters, or more). In some embodiments, a maximum diameter of tip 42 of center member 30 comprises a diameter of 25 to 70 millimeters (e.g., 50 millimeters); and in other embodiments, a maximum diameter of tip 42 of center member 30 can be less than 25 millimeters (e.g., 20, 15, 10 millimeters, or less) or more than 70 millimeters (e.g., 75, 80, 85 millimeters, or more).

[0032] In the embodiment shown, combustion apparatus 10 further comprises first outer member 54. First outer member 54 includes body 58 coupled to base 14 (e.g., upper latitudinal member 22). In the embodiment shown, body 58 of first outer member 54 is coupled to base 14 (e.g., upper latitudinal member 22) by screws 60. However, in some embodiments, body 58 of first outer member 54 can be coupled to base 14 (e.g., upper latitudinal member 22) in any suitable way (e.g., bolts, nails, adhesives, welds, and the like); and in other embodiments, base 14 (e.g., upper latitudinal member 22) and first outer member 54 can be integral (e.g., formed of the same piece of material). In the embodiment shown, body 58 of first outer member 54 is substantially cylindrical. First outer member 54 also includes tip 62, which is integral with body 54. In the embodiment shown, tip 62 of first

outer member 54 is substantially curved. In the embodiment shown, at least a portion of tip 42 of center member 30 is farther from base 14 than tip 62 of first outer member 54. Further, in the embodiment shown, at least a portion of tip 62 of first outer member 54 extends toward tip 42 of center member 30. In some embodiments, first outer member 54 comprises a length of 230 to 300 millimeters (e.g., 265 millimeters); and in other embodiments, a length of first outer member 54 can be less than 230 millimeters (e.g., 235, 225, 220 millimeters, or less) or more than 300 millimeters (e.g., 305, 310, 315 millimeters, or more). In some embodiments, first outer member 54 comprises a diameter of 70 to 120 millimeters (e.g., 96 millimeters); and in other embodiments, a diameter of first outer member 54 can be less than 70 millimeters (e.g., 65, 60, 55 millimeters, or less) or more than 120 millimeters (e.g., 125, 130, 135 millimeters, or more). In the embodiment shown, first outer member 54 further comprises bore 66, which is concentric with the longitudinal axis of center member 30. Bore 66 extends through body 58 and tip 62. Furthermore, first outer member 54 is positioned such that channel 70 (a portion of bore 66) is defined between first outer member 54 and center member 30. For example, in some embodiments, channel 70 can comprise a width of 1 and 5 millimeters (e.g., 3 millimeters). Such widths of channel 70 can be used, for example, with gaseous fuels and air. As another example, a width of channel 70 near tip 42 of center member 30 and tip 62 of first outer member 54 can be equal to or less than a quenching distance. In other embodiments, a width of channel 70 near tip 42 of center member 30 and tip 62 of first outer member 54 can be equal to or greater than a quenching distance. In some embodiments, bore 66 of first outer member 54 comprises a diameter of 20 to 80 millimeters (e.g., 56 millimeters); and in other embodiments, a diameter of bore 66 can be less than 20 millimeters (e.g., 15, 10, 5 millimeters, or less) or more than 80 millimeters (e.g., 85, 90, 95 millimeters, or more). Apparatus 10 is configured to permit fluid to enter apparatus 10 through inlets 26 and to move through channel 70 (e.g., in the embodiment shown, between body 34 and body 58 and also between at least a portion of tip 42 and at least a portion of tip 62) and out of tip 62 of first outer member 54.

[0033] In the embodiment shown, combustion apparatus 10 further comprises second outer member 74. Second outer member 74 includes body 78 coupled to base 14 (e.g., upper latitudinal member 22). Body 78 of second outer member 74 can be coupled to base 14 (e.g., upper latitudinal member 22) in any suitable way (e.g., screws, bolts, nails, adhesives, welds, and the like); and in other embodiments, base 14 (e.g., upper latitudinal member 22) and second outer member 74 can be integral (e.g., formed of the same piece of material). In the embodiment shown in FIG. 1, apparatus 10 comprises inlets 80 extending through a portion

of second outer member 74. Apparatus 10 can comprise any number of inlets 80, such as, for example, one, two, three, four, five, six, or more inlets 80. Inlets 80 are in fluid communication with apparatus 10 such that fluid can enter apparatus 10 (e.g., into channel 90) through inlets 80. In the embodiment shown, body 78 of second outer member 74 is substantially cylindrical. Second outer member 74 also includes tip 82, which is integral with body 74. In the embodiment shown, tip 82 of second outer member 74 is substantially curved. Tip 62 of first outer member 54 comprises a different curvature than tip 82 of second outer member 74, though in some embodiments, tip 62 and tip 82 can comprise the same or similar curvature. In the embodiment shown, at least a portion of tip 42 of center member 30 is farther from base 14 than tip 82 of second outer member 74. Further, in the embodiment shown, at least a portion of tip 82 of second outer member 74 extends toward tip 42 of center member 30. In some embodiments, second outer member 74 comprises a length of 190 to 260 millimeters (e.g., 228 millimeters); and in other embodiments, a length of second outer member 74 can be less than 190 millimeters (e.g., 185, 180, 175 millimeters, or less) or more than 260 millimeters (e.g., 265, 270, 275 millimeters, or more). In some embodiments, second outer member 74 comprises a diameter of 110 to 160 millimeters (e.g., 131.5 millimeters); and in other embodiments, a diameter of second outer member 74 can be less than 110 millimeters (e.g., 105, 100, 95 millimeters, or less) or more than 160 millimeters (e.g., 165, 170, 175 millimeters, or more). In the embodiment shown, second outer member 74 further comprises bore 86, which is concentric with the longitudinal axis of center member 30. Bore 86 extends through body 78 and tip 82. Furthermore, second outer member 74 is positioned such that channel 90 (a portion of bore 86) is defined between first outer member 54 and second outer member 74. For example, in some embodiments, channel 90 can comprise a width of 2 and 8 millimeters (e.g., 5 millimeters). Such widths of channel 90 can be used, for example, with gaseous fuels and air. As another example, a width of channel 90 near tip 42 of center member 30 and/or tip 62 of first outer member 54 can be equal to or less than a quenching distance. In other embodiments, a width of channel 90 near tip 42 of center member 30 and/or tip 62 of first outer member 54 can be equal to or greater than a quenching distance. In some embodiments, bore 86 of second outer member 74 comprises a diameter of 70 to 140 millimeters (e.g., 106 millimeters); and in other embodiments, a diameter of bore 86 can be less than 70 millimeters (e.g., 65, 60, 55 millimeters, or less) or more than 140 millimeters (e.g., 145, 150, 155 millimeters, or more). Apparatus 10 is configured to permit fluid to enter apparatus 10 through inlets 80 and to move through channel 90 (e.g., in the

embodiment shown, between body 58 and body 78 and also between at least a portion of tip 42 and at least a portion of tip 82) and out of tip 82 of second outer member 74.

[0034] In the embodiment shown, combustion apparatus 10 further comprises third outer member 94. Third outer member 94 is coupled to second outer member 74. Third outer member 94 can be coupled to second outer member 74 in any suitable way (e.g., screws, bolts, nails, adhesives, welds, and the like); and in other embodiments, second outer member 74 and third outer member 94 can be integral (e.g., formed of the same piece of material). In the embodiment shown in FIG. 1, apparatus 10 comprises inlets 98 extending through a portion of third outer member 94. Apparatus 10 can comprise any number of inlets 98, such as, for example, one, two, three, four, five, six, or more inlets 98. Inlets 98 are in fluid communication with apparatus 10 such that fluid can enter apparatus 10 through inlets 98. In the embodiment shown, third outer member 94 is substantially cylindrical. Third outer member 94 further comprises bore 102, which is concentric with the longitudinal axis of center member 30. Furthermore, third outer member 94 is positioned such that channel 106 (a portion of bore 102) is defined between second outer member 74 and third outer member 94. Apparatus 10 is configured to permit fluid to enter apparatus 10 through inlets 98 and to move through channel 106 and out of third outer member 94, such as, for example, if it is desirable to supply secondary fluid (e.g., air) to apparatus 10.

[0035] As explained above, apparatus 10 is configured to permit fluid to move through inlets 26, into channel 70, and out of tip 62 of first outer member 54. Further, apparatus 10 is configured to permit fluid to move through inlets 80, into channel 90, and out of tip 82 of second outer member 74. Apparatus 10 is configured such that fluid moving out of tip 62 of first outer member 54 and fluid moving out of tip 82 of second outer member 74 passes over at least a portion of tip 42 of center member 30 and mixes such that at least some fluid from both tip 62 and tip 82 recirculates (e.g., in a recirculation zone) near tip 42 of center member 30. For example, in some embodiments, a first fluid can move through inlets 26, into channel 70, and out of tip 62 of first outer member 54, and a second fluid can move through inlets 80, into channel 90, and out of tip 82 of second outer member 74 such that the first fluid and the second fluid can mix (e.g., near tip 42 of center member 30) and, if ignited, combust.

[0036] Fluid moving through apparatus 10 can be non-premixed fluid, partially premixed fluid, and/or premixed fluid. For example, in a non-premixed fluid embodiment, fuel (e.g., methane, propane, hydrogen, ethylene, and the like) can be introduced through inlets 26, into channel 70, and out of tip 62 of first outer member 54, and oxidizer (e.g., air,

oxygen, and the like) can be introduced through inlets 80, into channel 90, and out of tip 82 of second outer member 74. As another example, oxidizer (e.g., air, oxygen, and the like) can be introduced through inlets 26, into channel 70, and out of tip 62 of first outer member 54, and fuel (e.g., methane, propane, hydrogen, ethylene, and the like) can be introduced through inlets 80, into channel 90, and out of tip 82 of second outer member 74. As a further example, in a partially premixed fluid embodiment, a mixture of fuel and oxidizer (e.g., a rich mixture) can be introduced through inlets 26, into channel 70, and out of tip 62 of first outer member 54, and an oxidizer (e.g., air, oxygen, and the like) can be introduced through inlets 80, into channel 90, and out of tip 82 of second outer member 74. As another example, in a premixed fluid embodiment, lean premixtures can be introduced through inlets 26, into channel 70, and out of tip 62 of first outer member 54, and rich premixtures can be introduced through inlets 80, into channel 90, and out of tip 82 of second outer member 74. In other premixed fluid embodiments, rich premixtures can be introduced through inlets 26, into channel 70, and out of tip 62 of first outer member 54, and lean premixtures can be introduced through inlets 80, into channel 90, and out of tip 82 of second outer member 74. The lean and rich premixtures can be inflammable mixtures (e.g., by increasing the strength of the rich premixture and reducing the strength of the lean premixture, for example, depending on a type of gaseous fuel), which can, for example, reduce the likelihood of flame flashback. In some embodiments, diluent fuel can also be used.

[0037] FIG. 3A depicts an embodiment of a portion of combustion apparatus 10a. Combustion apparatus 10a comprises center member 30a having a longitudinal axis. Center member 30a includes body 34a and tip 42a, which is integral with body 34a. In the embodiment shown, tip 42a of center member 30a is substantially hemispherical. Tip 42a comprises first end 46a, which is proximal to body 34a, and second end 50a, which is distal to body 34a. Further, in the embodiment shown, combustion apparatus 10a comprises first outer member 54a. First outer member 54a includes body 58a, which is substantially cylindrical, and tip 62a, which is integral with body 54a and which is substantially curved. In the embodiment shown, at least a portion of tip 62a of first outer member 54a extends toward tip 42a of center member 30a. In the embodiment shown, first outer member 54a further comprises bore 66a, which is concentric with the longitudinal axis of center member 30a. Bore 66a extends through body 58a and tip 62a. Furthermore, first outer member 54a is positioned such that channel 70a (a portion of bore 66a) is defined between first outer member 54a and center member 30a. Apparatus 10a is configured to permit fluid to move through channel 70a and out of tip 62a of first outer member 54a. Combustion apparatus 10a

further comprises second outer member 74a. Second outer member 74a includes body 78a, which is substantially cylindrical, and tip 82a, which is integral with body 74a and which is substantially curved. In FIG. 3A, tip 62a of first outer member 54a comprises a different curvature than tip 82a of second outer member 74a, though in some embodiments, tip 62a and tip 82a can comprise the same or similar curvature. In the embodiment shown, at least a portion of tip 82a of second outer member 74a extends toward tip 42a of center member 30a. Second outer member 74a further comprises bore 86a, which is concentric with the longitudinal axis of center member 30a. Bore 86a extends through body 78a and tip 82a. Second outer member 74a is positioned such that channel 90a (a portion of bore 86a) is defined between first outer member 54a and second outer member 74a. Apparatus 10a is configured to permit fluid to move through channel 90a and out of tip 82a of second outer member 74a.

[0038] FIG. 3B depicts an embodiment of a portion of combustion apparatus 10b. Combustion apparatus 10b comprises center member 30b having a longitudinal axis. Center member 30b includes body 34b and tip 42b, which is integral with body 34b. In the embodiment shown, tip 42b of center member 30b is substantially hemispherical. Tip 42b comprises first end 46b, which is proximal to body 34b, and second end 50b, which is distal to body 34b. Further, in the embodiment shown, combustion apparatus 10b comprises first outer member 54b. First outer member 54b includes body 58b, which is substantially cylindrical, and tip 62b, which is integral with body 54b and which is substantially curved. In the embodiment shown, at least a portion of tip 62b of first outer member 54b extends toward tip 42b of center member 30b. In the embodiment shown, first outer member 54b further comprises bore 66b, which is concentric with the longitudinal axis of center member 30b. Bore 66b extends through body 58b and tip 62b. Furthermore, first outer member 54b is positioned such that channel 70b (a portion of bore 66b) is defined between first outer member 54b and center member 30b. Apparatus 10b is configured to permit fluid to move through channel 70b and out of tip 62b of first outer member 54b. Combustion apparatus 10b further comprises second outer member 74b. Second outer member 74b includes body 78b, which is substantially cylindrical, and tip 82b, which is integral with body 74b and which is substantially curved. In FIG. 3B, tip 62b of first outer member 54b comprises a different curvature than tip 82b of second outer member 74b, though in some embodiments, tip 62b and tip 82b can comprise the same or similar curvature. In the embodiment shown, at least a portion of tip 82b of second outer member 74b extends toward tip 42b of center member 30b. Second outer member 74b further comprises bore 86b, which is concentric with the

longitudinal axis of center member 30b. Bore 86b extends through body 78b and tip 82b. Second outer member 74b is positioned such that channel 90b (a portion of bore 86b) is defined between first outer member 54b and second outer member 74b. Apparatus 10b is configured to permit fluid to move through channel 90b and out of tip 82b of second outer member 74b.

[0039] As depicted by the double-sided arrows in FIGS. 3A-3B, the present combustion apparatuses and components of the such apparatuses can be adjustable. Using FIG. 3A as an example, center member 30a, first outer member 54a, and/or second outer member 74a can be adjustable (e.g., along the longitudinal axis of center member 30a) with respect to one or more of the others (or with respect to a base, an example of which is described with respect to FIG. 1) such that at least a portion of channel 70a (e.g., the portion of channel 70a near tip 42a and tip 62a) and/or at least a portion of channel 90a (e.g., the portion of channel 90a near tip 42a and tip 82a) changes in width. For example, if center member 30a is adjustable and first outer member 54a and/or second outer member 74a is fixed, center member 30a can be adjusted (e.g., longitudinally) such that at least a portion of channel 70a and/or at least a portion of channel 90a increases or decreases in width. As another example, if center member 30a is fixed and first outer member 54a and/or second outer member 74a is adjustable, first outer member 54a and/or second outer member 74a can be adjusted (e.g., longitudinally) such that at least a portion of channel 70a and/or channel 90a, respectively, increases or decreases in width. In some embodiments, a center member, a first outer member, and a second outer member can all be adjustable. Such adjustability can, for example, increase control of flame velocity and flame stability. As another example, the width of a channel can be adjusted comparably to the quenching distance (e.g., corresponding to used fuel), which can prevent flashback.

[0040] FIGS. 4A-4E depict other embodiments of a portion of combustion apparatuses – and more specifically, other embodiments of a portion of a center member. For example, FIG. 4A depicts center member 30c having a longitudinal axis. Center member 30c includes body 34c and tip 42c, which is integral with body 34c. In the embodiment shown, tip 42c of center member 30c is substantially hemispherical. Tip 42c comprises first end 46c, which is proximal to body 34c, and second end 50c, which is distal to body 34c. In the embodiment shown in FIG. 4A, second end 50c of tip 42c is substantially concave. Similarly, in the embodiment shown in FIG. 1, second end 50 of tip 42 is substantially concave. The diameter of the concave portion of the second end of a tip can be varied, depending on, for example, a desired size or spatial extent of a recirculation zone, a desired

flame appearance, a desired flame height, and/or a desired flame stability. For example, in some embodiments, a diameter of the concave portion of the second end of a tip can be 16 to 32 millimeters (e.g., 24 millimeters). A concave configuration of a second end of a tip of a center member (e.g., such as those depicted in FIGS. 1 and 4A) can, for example, increase flame stability, encourage recirculation of fluid (e.g., due to a greater or lesser amount of space for recirculation near a second end of a tip of a center member), increase the burner load, alter the flame appearance, and alter the flame height.

[0041] As depicted in FIG. 4B, a tip of a center member may not comprise a concave portion. For example, center member 30d has a longitudinal axis and includes body 34d and tip 42d, which is integral with body 34d. In the embodiment shown, tip 42d of center member 30d is substantially hemispherical. Tip 42d comprises first end 46d, which is proximal to body 34d, and second end 50d, which is distal to body 34d.

[0042] In some embodiments, as depicted in FIG. 4C, center member 30e comprises a longitudinal axis and bore 110e, which is concentric with the longitudinal axis of center member 30e. Center member 30e includes body 34e and tip 42e, which is integral with body 34e. In the embodiment shown, tip 42e of center member 30e is substantially hemispherical. Tip 42e comprises first end 46e, which is proximal to body 34e, and second end 50e, which is distal to body 34e. Bore 110e extends through body 34e and tip 42e of center member 30e. Center member 30e is configured to permit fluid to move through bore 110e and out of tip 42e, which can, for example, increase flame stability (e.g., by supplying a percentage of fuel to fluid (e.g., recirculating fluid) near tip 42e of center member 30e, increasing the temperature of such fluid such that flame quenching is reduced at high strain regions) and aerodynamically strengthen a recirculation zone near tip 42e of center member 30e. For example, fuel can be introduced to bore 110e of center member 30e such that the fuel can mix with other fluids near second end 50e of tip 42e of center member 30e (e.g., in a recirculation zone).

[0043] As another example depicted in FIG. 4D, center member 30f has a longitudinal axis, body 34f, and tip 42f, which is integral with body 34f. In the embodiment shown, tip 42f of center member 30f is substantially hemispherical. Tip 42f comprises first end 46f, which is proximal to body 34f, and second end 50f, which is distal to body 34f. In the embodiment shown, swirling vane 114f is coupled to center member 30f to, for example, encourage a swirling flow and mixing of fluid. In some embodiments, where center member 30f comprises a bore concentric with the longitudinal axis of center member 30f and extending through body 34f and tip 42f of center member 30f (e.g., similar to that depicted in

FIG. 4C), swirling vane 114f is configured to disturb fluid moving through the bore of center member 30f. In other embodiments, swirling vane 114f extends at least partially into a first channel defined by center member 30f and a first outer member such that fluid moving through the first channel is disturbed. In still other embodiments, swirling vane 114f extends at least partially into a second channel defined by a first outer member and a second outer member such that fluid moving through the second channel and/or the first channel is disturbed.

[0044] Some embodiments of the present combustion apparatuses can be configured to increase swirling flow and mixing of fluid by introducing fluid to a combustion apparatus substantially perpendicular to a given flow, a given bore, and/or a given channel (e.g., flow through a bore of a center member, through a first channel defined by a center member and a concentric first outer member, through a second channel defined by the first outer member and a concentric second outer member, etc.). Such introduction of fluid can, for example, give the flow field a tangential velocity component near the tip of the center member, which encourages recirculation of fluid near the tip of the center member.

[0045] As depicted in FIG. 4E, center member 30g includes a longitudinal axis, body 34g, and tip 42g, which is integral with body 34g. In the embodiment shown, tip 42g of center member 30g is substantially hemispherical. Tip 42g comprises first end 46g, which is proximal to body 34g, and second end 50g, which is distal to body 34g. In the embodiment shown, spark plug 118g is coupled to center member 30g. If activated, spark plug 118g can ignite fluid near tip 42g of center member 30g (e.g., a mixture of fluid from a bore of center member 30g, fluid from a first channel defined by a center member and a concentric first outer member, and/or fluid from a second channel defined by the first outer member and a concentric second outer member).

[0046] FIG. 5 depicts another embodiment of a portion of combustion apparatuses – and more specifically, another embodiment of a portion of a first outer member. First outer member 54h depicted in FIG. 5 comprises body 58h, which is substantially cylindrical, and tip 62h, which is integral with body 58h and which is substantially curved. In the embodiment shown, first outer member 54h further comprises bore 66h that extends through body 58h and tip 62h. First outer member 54h can be positioned concentric with a longitudinal axis of a center member (e.g., such as any of the center members depicted in FIGS. 1-4E) such that a channel (a portion of bore 66h) is defined between first outer member 54h and the center member. First outer member 54h is configured to permit fluid to move through the channel and out of tip 62h of first outer member 54h.

[0047] FIG. 6 depicts another embodiment of a portion of combustion apparatuses – and more specifically, another embodiment of a portion of a second outer member. Second outer member 74i depicted in FIG. 5 comprises body 78i, which is substantially cylindrical, and tip 82i, which is integral with body 78i and which is substantially curved. In the
5 embodiment shown, second outer member 74i further comprises bore 86i that extends through body 78i and tip 82i. Second outer member 74i can be positioned concentric with a longitudinal axis of a center member (e.g., such as any of the center members depicted in FIGS. 1-4E and 8) such that, if a first outer member (e.g., such as any of the first outer members depicted in FIGS. 1-3B, 5, and 8) is also positioned concentric with a longitudinal
10 axis of a center member, a channel (a portion of bore 86i) is defined between the first outer member and second outer member 74i. Second outer member 74i is configured to permit fluid to move through the channel and out of tip 82i of second outer member 74i.

[0048] If fluid flows over a curved surface (e.g., over two sides of a curved surface, such as over a circle, as illustrated in FIG. 7), the Coanda effect can be observed, which is
15 encouraged by the disclosed combustion apparatuses. Fluid flow over curved surfaces generates a region of low pressure, which results in a relative delay in fluid separation. As fluid approaches an end of the curved surface, the fluid begins to recover static pressure and approach ambient pressure. A recirculation zone can form near the end of the curved surface. If fluid flows over two sides of a curved surface, such as a circle, the fluid on either side of
20 the curved surface can mix in the recirculation zone (e.g., inducing entrainment) and continue to mix downstream from the recirculation zone.

[0049] FIG. 8 depicts an embodiment of a portion of combustion apparatus 10j. Combustion apparatus 10j comprises center member 30j having a longitudinal axis. Center member 30j includes body 34j and tip 42j, which is integral with body 34j. In the
25 embodiment shown, tip 42j of center member 30j is substantially hemispherical. Tip 42j comprises first end 46j, which is proximal to body 34j, and second end 50j, which is distal to body 34j. In the embodiment shown in FIG. 8, second end 50j of tip 42j is substantially concave. Further, in the embodiment shown, combustion apparatus 10j comprises first outer member 54j. In the embodiment shown, first outer member 54j includes tip 62j, which is
30 substantially curved. In the embodiment shown, first outer member 54j further comprises bore 66j, which is concentric with the longitudinal axis of center member 30j. Bore 66j extends through tip 62j. Furthermore, first outer member 54j is positioned such that channel 70j (a portion of bore 66j) is defined between first outer member 54j and center member 30j. Apparatus 10j is configured to permit fluid to move through channel 70j and out of tip 62j of

first outer member 54j. Combustion apparatus 10j further comprises second outer member 74j. Second outer member 74j includes tip 82j, which is substantially curved. In FIG. 8, tip 62j of first outer member 54j and tip 82j of second outer member 74j comprise a similar curvature; though, in other embodiments, tip 62j and tip 82j can comprise a different curvature. Second outer member 74j further comprises bore 86j, which is concentric with the longitudinal axis of center member 30j. Bore 86j extends through tip 82j. Second outer member 74j is positioned such that channel 90j (a portion of bore 86j) is defined between first outer member 54j and second outer member 74j. Apparatus 10j is configured to permit fluid to move through channel 90j and out of tip 82j of second outer member 74j. The embodiment shown in FIG. 8 demonstrates an example of the Coanda effect, which is encouraged by the combustion apparatus of FIG. 8, as well as the other combustion apparatuses described and depicted in the present disclosure. Fluid flow over curved surfaces of tip 42j, tip 62j, and tip 82j generates a region of low pressure, which results in a relative delay in fluid separation. As fluid approaches an end of a curved surface, the fluid begins to recover static pressure and approach ambient pressure. As depicted in FIG. 8, a recirculation zone is formed near the substantially concave portion of tip 42j of center member 30j. Fluid can mix in the recirculation zone (e.g., inducing entrainment) and continue to mix downstream from the recirculation zone.

[0050] FIG. 9 depicts experimental results from the use of one embodiment of the present combustion apparatuses that comprises a center member having a longitudinal axis and a substantially hemispherical tip, a first outer member having a bore and positioned such that a first channel is defined between the first outer member and the center member, and a second outer member having a bore and positioned such that a second channel is defined between the second outer member and the first outer member.

[0051] Some embodiments of the present methods comprise introducing a first fluid into a first channel (e.g., channel 70) defined by a center member (e.g., center member 30) having a tip (e.g., tip 42), where at least a portion of the tip is substantially hemispherical, and a first outer member (e.g., first outer member 54); introducing a second fluid into a second channel (e.g., channel 90) defined by the first outer member and a second outer member (e.g., second outer member 74); permitting the first fluid and the second fluid to flow over the tip of the center member and to mix; and igniting the mixture of the first fluid and the second fluid. In some embodiments, the method comprises introducing the first fluid into the first channel substantially perpendicular to the first channel. In some embodiments, the method comprises introducing the second fluid into the second channel substantially perpendicular to

the second channel. In some embodiments, the method comprises adjusting the center member with respect to the first outer member and the second outer member such that at least a portion of the first channel and the second channel changes in width. In some embodiments, the method comprises adjusting the first outer member with respect to the center member such that at least a portion of the first channel changes in width. In some embodiments, a width of the at least a portion of the first channel is similar to (e.g., equal to, greater than, or less than) a quenching distance. In some embodiments, the method comprises adjusting the second outer member with respect to the center member such that at least a portion of the second channel changes in width. In some embodiments, a width of the at least a portion of the second channel is similar to (e.g., equal to, greater than, or less than) a quenching distance. In some embodiments, a spark plug (e.g., spark plug 118g) is coupled to the center member, and the method further comprising igniting the mixture of the first fluid and the second fluid with the spark plug. In some embodiments, the first fluid comprises fuel and the second fluid comprises air. In some embodiments, the first fluid comprises air and the second fluid comprises fuel. In some embodiments, the first fluid comprises fuel and the second fluid comprises an oxidizer. In some embodiments, the first fluid comprises an oxidizer and the second fluid comprises fuel. In some embodiments, the first fluid comprises a mixture of air and fuel and the second fluid comprises a mixture of fuel and air. In some embodiments, the first fluid comprises a mixture of oxidizer and fuel and the second fluid comprises a mixture of fuel and oxidizer. In some embodiments, the first fluid comprises a lean pre-mixture and the second fluid comprises a rich pre-mixture. In some embodiments, the first fluid comprises a rich pre-mixture and the second fluid comprises a lean pre-mixture. In some embodiments, the lean pre-mixture and the rich pre-mixture are inflammable.

[0052] Some embodiments of the present methods comprise introducing a first fluid into a first channel (e.g., channel 70) defined by a center member (e.g., center member 30e) and a first outer member (e.g., first outer member 54); introducing a second fluid into a second channel (e.g., channel 90) defined by the first outer member and a second outer member (e.g., second outer member 74); introducing a third fluid through a bore (e.g., bore 110e) of the center member, where the center member has a longitudinal axis and comprises: a body (e.g., body 34e), where at least a portion of the body is substantially cylindrical; and a tip (e.g., tip 42e) integral with the body, where at least a portion of the tip is substantially hemispherical, where the bore of the center member is concentric with the longitudinal axis of the center member and extends through the body and the tip; permitting the first fluid and the second fluid to flow over the tip of the center member and to mix with the third fluid; and

igniting the mixture of the first fluid, the second fluid, and the third fluid. In some embodiments, the method comprises introducing the first fluid into the first channel substantially perpendicular to the first channel. In some embodiments, the method comprises introducing the second fluid into the second channel substantially perpendicular to the second channel. In some embodiments, the method comprises adjusting the center member with respect to the first outer member and the second outer member such that at least a portion of the first channel and the second channel changes in width. In some embodiments, the method comprises adjusting the first outer member with respect to the center member such that at least a portion of the first channel changes in width. In some embodiments, a width of the at least a portion of the second channel is similar to (e.g., equal to, greater than, or less than) a quenching distance. In some embodiments,, the method comprises adjusting the second outer member with respect to the center member such that at least a portion of the second channel changes in width. In some embodiments, a width of the at least a portion of the first channel is similar to (e.g., equal to, greater than, or less than) a quenching distance. In some embodiments, a spark plug (e.g., spark plug 118g) is coupled to the center member and the method further comprising igniting the mixture of the first fluid, the second fluid, and the third fluid with the spark plug. In some embodiments, the first fluid comprises fuel and the second fluid comprises air. In some embodiments, the first fluid comprises air and the second fluid comprises fuel. In some embodiments, the first fluid comprises fuel and the second fluid comprises an oxidizer. In some embodiments, the first fluid comprises an oxidizer and the second fluid comprises fuel. In some embodiments, the first fluid comprises a mixture of air and fuel and the second fluid comprises a mixture of fuel and air. In some embodiments, the first fluid comprises a mixture of oxidizer and fuel and the second fluid comprises a mixture of fuel and oxidizer. In some embodiments, the first fluid comprises a lean pre-mixture and the second fluid comprises a rich pre-mixture. In some embodiments, the first fluid comprises a rich pre-mixture and the second fluid comprises a lean pre-mixture. In some embodiments, the lean pre-mixture and the rich pre-mixture are inflammable. In some embodiments, the first fluid comprises fuel, the second fluid comprises air, and the third fluid comprises fuel. In some embodiments, the first fluid comprises air, the second fluid comprises fuel, and the third fluid comprises fuel.

[0053] The above specification and examples provide a complete description of the structure and use of exemplary embodiments. Although certain embodiments have been described above with a certain degree of particularity, or with reference to one or more individual embodiments, those skilled in the art could make numerous alterations to the

disclosed embodiments without departing from the scope of this invention. As such, the various illustrative embodiments of the present apparatuses and methods are not intended to be limited to the particular forms disclosed. Rather, they include all modifications and alternatives falling within the scope of the claims, and embodiments other than the ones
5 shown may include some or all of the features of the depicted embodiments. For example, components may be combined as a unitary structure and/or connections may be substituted. Further, where appropriate, aspects of any of the examples described above may be combined with aspects of any of the other examples described to form further examples having comparable or different properties and addressing the same or different problems. Similarly,
10 it will be understood that the benefits and advantages described above may relate to one embodiment or may relate to several embodiments.

[0054] The claims are not intended to include, and should not be interpreted to include, means-plus- or step-plus-function limitations, unless such a limitation is explicitly recited in a given claim using the phrase(s) “means for” or “step for,” respectively.

CLAIMS

1. A combustion apparatus comprising:
 - a center member having a longitudinal axis and comprising:
 - a body, where at least a portion of the body is substantially cylindrical; and
 - a tip integral with the body, where at least a portion of the tip is substantially hemispherical;
 - a first outer member comprising:
 - a body;
 - a tip integral with the body; and
 - a bore concentric with the longitudinal axis of the center member;where the first outer member is positioned such that a first channel is defined between the first outer member and the center member; and
 - a second outer member comprising:
 - a body;
 - a tip integral with the body; and
 - a bore concentric with the longitudinal axis of the center member;where the second outer member is positioned such that a second channel is defined between the second outer member and the first outer member;where the apparatus is configured to:
 - permit fluid to move through the first channel and out of the tip of the first outer member; and
 - permit fluid to move through the second channel and out of the tip of the second outer member.
2. The apparatus of claim 1, where at least a portion of the tip of the first outer member and at least a portion of the tip of the second outer member each extends toward the tip of the center member.
3. The apparatus of claim 1, where the center member is 250 to 320 millimeters in length.
4. The apparatus of claim 1, where the center member is 285 millimeters in length.
5. The apparatus of claim 1, where the center member comprises a diameter of 25 to 75 millimeters.

6. The apparatus of claim 1, where the center member comprises a diameter of 50 millimeters.
7. The apparatus of claim 1, where the first outer member is 230 to 300 millimeters in length.
8. The apparatus of claim 1, where the first outer member is 265 millimeters in length.
9. The apparatus of claim 1, where the bore of the first outer member comprises a diameter of 20 to 80 millimeters.
10. The apparatus of claim 1, where the bore of the first outer member comprises a diameter of 56 millimeters.
11. The apparatus of claim 1, where the first outer member comprises a diameter of 70 to 120 millimeters.
12. The apparatus of claim 1, where the first outer member comprises a diameter of 96 millimeters.
13. The apparatus of claim 1, where the second outer member is 190 to 260 millimeters in length.
14. The apparatus of claim 1, where the second outer member is 228 millimeters in length.
15. The apparatus of claim 1, where the bore of the second outer member comprises a diameter of 70 to 140 millimeters.
16. The apparatus of claim 1, where the bore of the second outer member comprises a diameter of 106 millimeters.
17. The apparatus of claim 1, where the second outer member comprises a diameter of 110 to 160 millimeters.
18. The apparatus of claim 1, where the second outer member comprises a diameter of 131.5 millimeters.
19. The apparatus of claim 1, where at least a portion of the first channel comprises a width of 3 millimeters.
20. The apparatus of claim 1, where at least a portion of the second channel comprises a width of 5 millimeters.

21. The apparatus of claim 1, where the center member is adjustable with respect to the first outer member and the second outer member such that at least a portion of the first channel and the second channel can change in width.
22. The apparatus of claim 1, where the first outer member is adjustable with respect to the center member such that at least a portion of the first channel can change in width.
23. The apparatus of claim 1, where the second outer member is adjustable with respect to the center member such that at least a portion of the second channel can change in width.
24. The apparatus of claim 1, further comprising:
 - four inlets in fluid communication with the first channel through which fluid can enter the first channel; and
 - four inlets in fluid communication with the second channel through which fluid can enter the second channel.
25. The apparatus of claim 1, where the tip of the center member has a first end and a second end, and the second end of the tip is substantially concave.
26. The apparatus of claim 1, further comprising:
 - a swirling vane coupled to the center member and extending at least partially into the first channel such that fluid moving through the first channel is disturbed.
27. The apparatus of claim 26, further comprising:
 - a swirling vane coupled to the center member and extending at least partially into the second channel such that fluid moving through the first channel and the second channel is disturbed.
28. The apparatus of claim 1, further comprising:
 - a swirling vane coupled to the center member, where if the center member comprises a bore concentric with the longitudinal axis of the center member and extending through the body and the tip of the center member, fluid moving through the bore of the center member is disturbed.
29. The apparatus of claim 1, where the first outer member is configured such that fluid can be introduced into the first channel substantially perpendicular to the first channel.
30. The apparatus of claim 1, where the second outer member is configured such that fluid can be introduced into the second channel substantially perpendicular to the second channel.

31. The apparatus of claim 1, further comprising:
a spark plug coupled to the center member.
32. An combustion apparatus comprising:
a center member having a longitudinal axis and comprising:
a body, where at least a portion of the body is substantially cylindrical;
a tip integral with the body, where at least a portion of the tip is substantially hemispherical; and
a bore concentric with the longitudinal axis of the center member, the bore extending through the body and the tip; and
a first outer member comprising:
a body;
a tip integral with the body; and
a bore concentric with the longitudinal axis of the center member;
where the first outer member is positioned such that a first channel is defined between the first outer member and the center member,
a second outer member comprising:
a body;
a tip integral with the body; and
a bore concentric with the longitudinal axis of the center member;
where the second outer member is positioned such that a second channel is defined between the second outer member and the first outer member;
where the apparatus is configured to:
permit fluid to move through the bore of the center member and out of the tip of the center member;
permit fluid to move through the first channel and out of the tip of the first outer member; and
permit fluid to move through the second channel and out of the tip of the second outer member.
33. The apparatus of claim 32, where at least a portion of the tip of the first outer member and at least a portion of the tip of the second outer member each extends toward the tip of the center member.
34. The apparatus of claim 32, where the center member is 250 to 320 millimeters in length.

35. The apparatus of claim 32, where the center member is 285 millimeters in length.
36. The apparatus of claim 32, where the center member comprises a diameter of 25 to 75 millimeters.
37. The apparatus of claim 32, where the center member comprises a diameter of 50 millimeters.
38. The apparatus of claim 32, where the first outer member is 230 to 300 millimeters in length.
39. The apparatus of claim 32, where the first outer member is 265 millimeters in length.
40. The apparatus of claim 32, where the bore of the first outer member comprises a diameter of 20 to 80 millimeters.
41. The apparatus of claim 32, where the bore of the first outer member comprises a diameter of 56 millimeters.
42. The apparatus of claim 32, where the first outer member comprises a diameter of 70 to 120 millimeters.
43. The apparatus of claim 32, where the first outer member comprises a diameter of 96 millimeters.
44. The apparatus of claim 32, where the second outer member is 190 to 260 millimeters in length.
45. The apparatus of claim 32, where the second outer member is 228 millimeters in length.
46. The apparatus of claim 32, where the bore of the second outer member comprises a diameter of 70 to 140 millimeters.
47. The apparatus of claim 32, where the bore of the second outer member comprises a diameter of 106 millimeters.
48. The apparatus of claim 32, where the second outer member comprises a diameter of 110 to 160 millimeters.
49. The apparatus of claim 32, where the second outer member comprises a diameter of 131.5 millimeters.

50. The apparatus of claim 32, where at least a portion of the first channel comprises a width of 3 millimeters.
51. The apparatus of claim 32, where at least a portion of the second channel comprises a width of 5 millimeters.
52. The apparatus of claim 32, where the center member is adjustable with respect to the first outer member and the second outer member such that at least a portion of the first channel and the second channel can change in width.
53. The apparatus of claim 32, where the first outer member is adjustable with respect to the center member such that at least a portion of the first channel can change in width.
54. The apparatus of claim 32, where the second outer member is adjustable with respect to the center member such that at least a portion of the second channel can change in width.
55. The apparatus of claim 32, further comprising:
 - four inlets in fluid communication with the first channel through which fluid can enter the first channel; and
 - four inlets in fluid communication with the second channel through which fluid can enter the second channel.
56. The apparatus of claim 32, where the tip of the center member has a first end and a second end, and the second end of the tip is substantially concave.
57. The apparatus of claim 1, further comprising:
 - a swirling vane coupled to the center member and extending at least partially into the first channel such that fluid moving through the first channel is disturbed.
58. The apparatus of claim 26, further comprising:
 - a swirling vane coupled to the center member and extending at least partially into the second channel such that fluid moving through the first channel and the second channel is disturbed.
59. The apparatus of claim 1, further comprising:
 - a swirling vane coupled to the center member such that fluid moving through the bore of the center member is disturbed.
60. The apparatus of claim 32, where the first outer member is configured such that fluid can be introduced into the first channel substantially perpendicular to the first channel.

61. The apparatus of claim 32, where the second outer member is configured such that fluid can be introduced into the second channel substantially perpendicular to the second channel.
62. The apparatus of claim 32, further comprising:
a spark plug coupled to the center member.
63. A combustion apparatus comprising:
a base; and
a center member having a longitudinal axis and comprising:
a body coupled to the base, where at least a portion of the body is substantially cylindrical; and
a tip integral with the body, where at least a portion of the tip is substantially hemispherical;
a first outer member comprising:
a body;
a tip integral with the body, where at least a portion of the tip of the center member is farther from the base than the tip of the first outer member;
and
a bore concentric with the longitudinal axis of the center member;
where the first outer member is positioned such that a first channel is defined between the first outer member and the center member; and
a second outer member comprising:
a body;
a tip integral with the body, where at least a portion of the tip of the center member is farther from the base than the tip of the second outer member; and
a bore concentric with the longitudinal axis of the center member;
where the second outer member is positioned such that a second channel is defined between the second outer member and the first outer member;
where the apparatus is configured to:
permit fluid to move through the first channel and out of the tip of the first outer member; and
permit fluid to move through the second channel and out of the tip of the second outer member.

64. The apparatus of claim 63, where at least a portion of the tip of the first outer member and at least a portion of the tip of the second outer member each extends toward the tip of the center member.
65. The apparatus of claim 63, where the center member is 250 to 320 millimeters in length.
66. The apparatus of claim 63, where the center member is 285 millimeters in length.
67. The apparatus of claim 63, where the center member comprises a diameter of 25 to 75 millimeters.
68. The apparatus of claim 63, where the center member comprises a diameter of 50 millimeters.
69. The apparatus of claim 63, where the first outer member is 230 to 300 millimeters in length.
70. The apparatus of claim 63, where the first outer member is 265 millimeters in length.
71. The apparatus of claim 63, where the bore of the first outer member comprises a diameter of 20 to 80 millimeters.
72. The apparatus of claim 63, where the bore of the first outer member comprises a diameter of 56 millimeters.
73. The apparatus of claim 63, where the first outer member comprises a diameter of 70 to 120 millimeters.
74. The apparatus of claim 63, where the first outer member comprises a diameter of 96 millimeters.
75. The apparatus of claim 63, where the second outer member is 190 to 260 millimeters in length.
76. The apparatus of claim 63, where the second outer member is 228 millimeters in length.
77. The apparatus of claim 63, where the bore of the second outer member comprises a diameter of 70 to 140 millimeters.
78. The apparatus of claim 63, where the bore of the second outer member comprises a diameter of 106 millimeters.

79. The apparatus of claim 63, where the second outer member comprises a diameter of 110 to 160 millimeters.
80. The apparatus of claim 63, where the second outer member comprises a diameter of 131.5 millimeters.
81. The apparatus of claim 63, where at least a portion of the first channel comprises a width of 3 millimeters.
82. The apparatus of claim 63, where at least a portion of the second channel comprises a width of 5 millimeters.
83. The apparatus of claim 63, where the center member is adjustable with respect to the first outer member and the second outer member such that at least a portion of the first channel and the second channel can change in width.
84. The apparatus of claim 63, where the first outer member is adjustable with respect to the center member such that at least a portion of the first channel can change in width.
85. The apparatus of claim 63, where the second outer member is adjustable with respect to the center member such that at least a portion of the second channel can change in width.
86. The apparatus of claim 63, further comprising:
four inlets in fluid communication with the first channel through which fluid can enter the first channel; and
four inlets in fluid communication with the second channel through which fluid can enter the second channel.
87. The apparatus of claim 63, where the tip of the center member has a first end and a second end, and the second end of the tip is substantially concave.
88. The apparatus of claim 1, further comprising:
a swirling vane coupled to the center member and extending at least partially into the first channel such that fluid moving through the first channel is disturbed.
89. The apparatus of claim 26, further comprising:
a swirling vane coupled to the center member and extending at least partially into the second channel such that fluid moving through the first channel and the second channel is disturbed.
90. The apparatus of claim 1, further comprising:

a swirling vane coupled to the center member, where if the center member comprises a bore concentric with the longitudinal axis of the center member and extending through the body and the tip of the center member, fluid moving through the bore of the center member is disturbed.

91. The apparatus of claim 63, where the first outer member is configured such that fluid can be introduced into the first channel substantially perpendicular to the first channel.
92. The apparatus of claim 63, where the second outer member is configured such that fluid can be introduced into the second channel substantially perpendicular to the second channel.
93. The apparatus of claim 63, further comprising:
a spark plug coupled to the center member.
94. A method for combustion comprising:
introducing a first fluid into a first channel defined by:
a center member having a tip, where at least a portion of the tip is substantially hemispherical; and
a first outer member;
introducing a second fluid into a second channel defined by the first outer member and a second outer member;
permitting the first fluid and the second fluid to flow over the tip of the center member and to mix; and
igniting the mixture of the first fluid and the second fluid.
95. The method of claim 94, further comprising:
introducing the first fluid into the first channel substantially perpendicular to the first channel.
96. The method of claim 94, further comprising:
introducing the second fluid into the second channel substantially perpendicular to the second channel.
97. The method of claim 94, further comprising:
adjusting the center member with respect to the first outer member and the second outer member such that at least a portion of the first channel and the second channel changes in width.

98. The method of claim 94, further comprising:
adjusting the first outer member with respect to the center member such that at least a portion of the first channel changes in width.
99. The method of claim 98, where a width of the at least a portion of the first channel is similar to a quenching distance.
100. The method of claim 94, further comprising:
adjusting the second outer member with respect to the center member such that at least a portion of the second channel changes in width.
101. The method of claim 100, where a width of the at least a portion of the second channel is similar to a quenching distance.
102. The method of claim 94, where a spark plug is coupled to the center member, the method further comprising:
igniting the mixture of the first fluid and the second fluid with the spark plug.
103. The method of claim 94, where the first fluid comprises fuel and the second fluid comprises air.
104. The method of claim 94, where the first fluid comprises air and the second fluid comprises fuel.
105. The method of claim 94, where the first fluid comprises fuel and the second fluid comprises an oxidizer.
106. The method of claim 94, where the first fluid comprises an oxidizer and the second fluid comprises fuel.
107. The method of claim 94, where the first fluid comprises a mixture of air and fuel and the second fluid comprises a mixture of fuel and air.
108. The method of claim 94, where the first fluid comprises a mixture of oxidizer and fuel and the second fluid comprises a mixture of fuel and oxidizer.
109. The method of claim 94, where the first fluid comprises a lean pre-mixture and the second fluid comprises a rich pre-mixture.
110. The method of claim 109, where the lean pre-mixture and the rich pre-mixture are inflammable.

111. The method of claim 94, where the first fluid comprises a rich pre-mixture and the second fluid comprises a lean pre-mixture.
112. The method of claim 111, where the lean pre-mixture and the rich pre-mixture are inflammable.
113. A method for combustion comprising:
introducing a first fluid into a first channel defined by a center member and a first outer member;
introducing a second fluid into a second channel defined by the first outer member and a second outer member;
introducing a third fluid through a bore of the center member, where the center member has a longitudinal axis and comprises:
a body, where at least a portion of the body is substantially cylindrical; and
a tip integral with the body, where at least a portion of the tip is substantially hemispherical;
where the bore of the center member is concentric with the longitudinal axis of the center member and extends through the body and the tip;
permitting the first fluid and the second fluid to flow over the tip of the center member and to mix with the third fluid; and
igniting the mixture of the first fluid, the second fluid, and the third fluid.
114. The method of claim 113, further comprising:
introducing the first fluid into the first channel substantially perpendicular to the first channel.
115. The method of claim 113, further comprising:
introducing the second fluid into the second channel substantially perpendicular to the second channel.
116. The method of claim 113, further comprising:
adjusting the center member with respect to the first outer member and the second outer member such that at least a portion of the first channel and the second channel changes in width.
117. The method of claim 113, further comprising:
adjusting the first outer member with respect to the center member such that at least a portion of the first channel changes in width.

118. The method of claim 117, where a width of the at least a portion of the second channel is similar to a quenching distance.
119. The method of claim 113, further comprising:
adjusting the second outer member with respect to the center member such that at least a portion of the second channel changes in width.
120. The method of claim 119, where a width of the at least a portion of the first channel is similar to a quenching distance.
121. The method of claim 113, where a spark plug is coupled to the center member, the method further comprising:
igniting the mixture of the first fluid, the second fluid, and the third fluid with the spark plug.
122. The method of claim 113, where the first fluid comprises fuel and the second fluid comprises air.
123. The method of claim 113, where the first fluid comprises air and the second fluid comprises fuel.
124. The method of claim 113, where the first fluid comprises fuel and the second fluid comprises an oxidizer.
125. The method of claim 113, where the first fluid comprises an oxidizer and the second fluid comprises fuel.
126. The method of claim 113, where the first fluid comprises a mixture of air and fuel and the second fluid comprises a mixture of fuel and air.
127. The method of claim 113, where the first fluid comprises a mixture of oxidizer and fuel and the second fluid comprises a mixture of fuel and oxidizer.
128. The method of claim 113, where the first fluid comprises a lean pre-mixture and the second fluid comprises a rich pre-mixture.
129. The method of claim 128, where the lean pre-mixture and the rich pre-mixture are inflammable.
130. The method of claim 113, where the first fluid comprises a rich pre-mixture and the second fluid comprises a lean pre-mixture.

131. The method of claim 130, where the lean pre-mixture and the rich pre-mixture are inflammable.

132. The method of claim 113, where the first fluid comprises fuel, the second fluid comprises air, and the third fluid comprises fuel.

133. The method of claim 113, where the first fluid comprises air, the second fluid comprises fuel, and the third fluid comprises fuel.

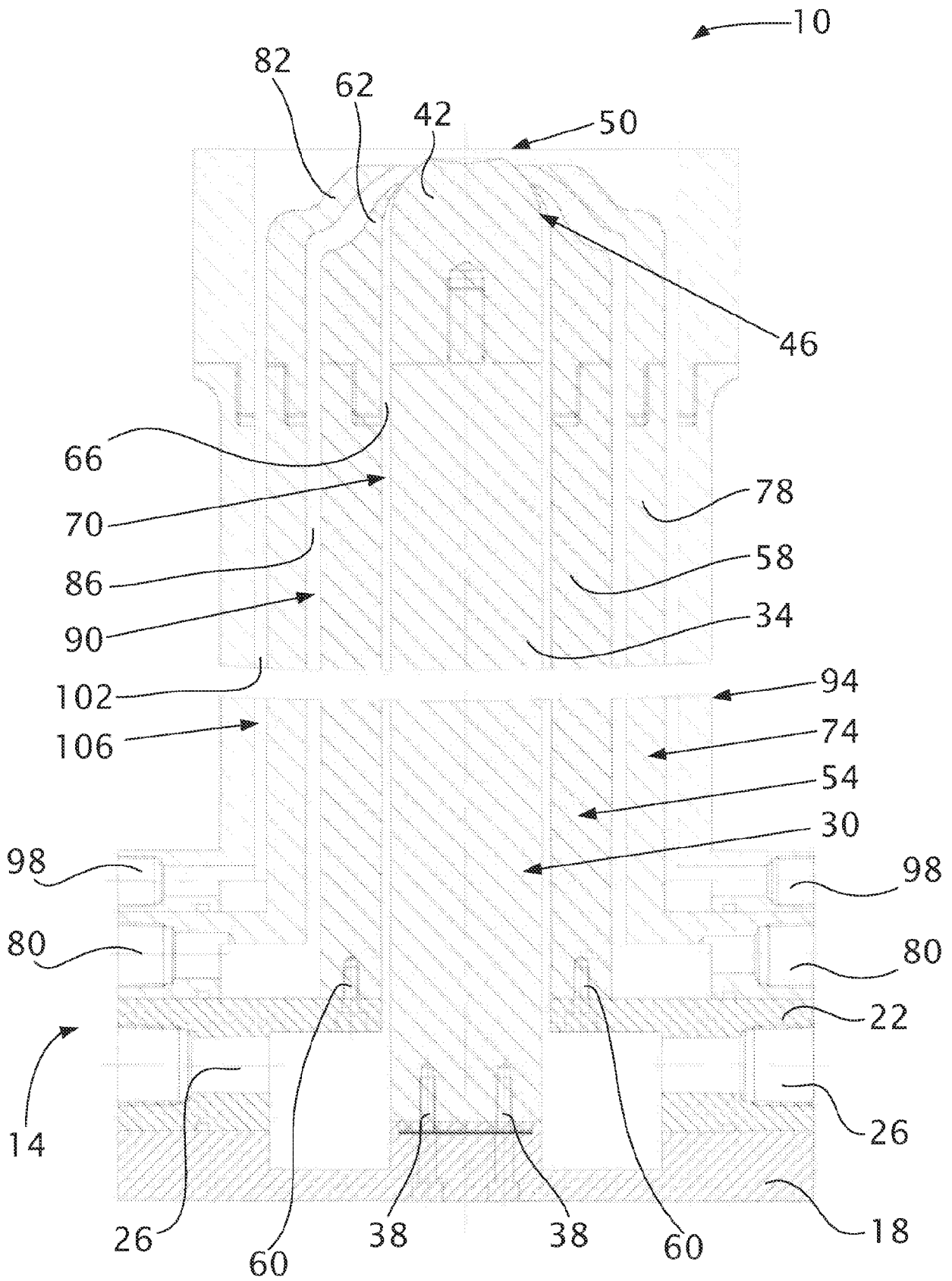

FIG. 1

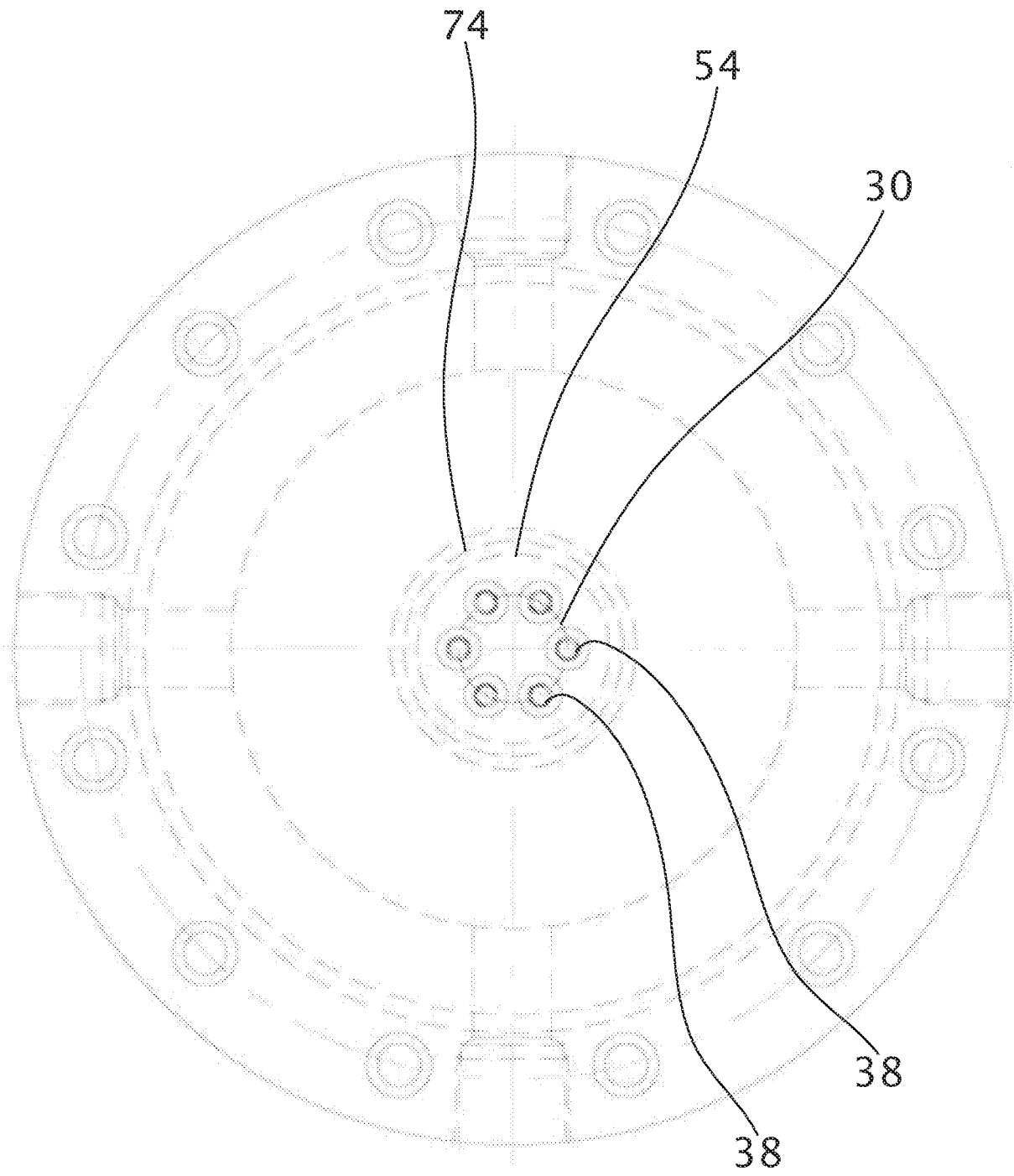

FIG. 2

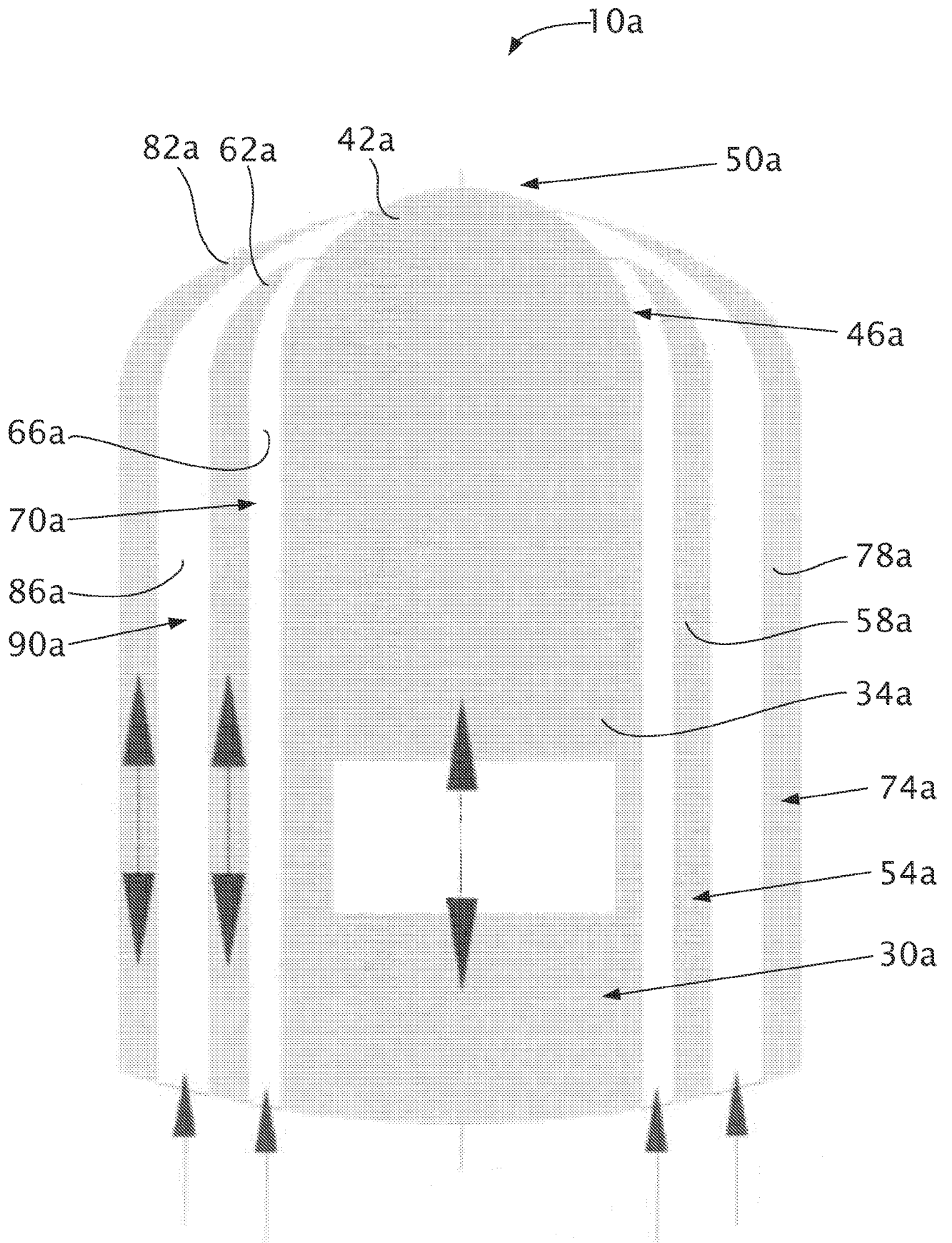

FIG. 3A

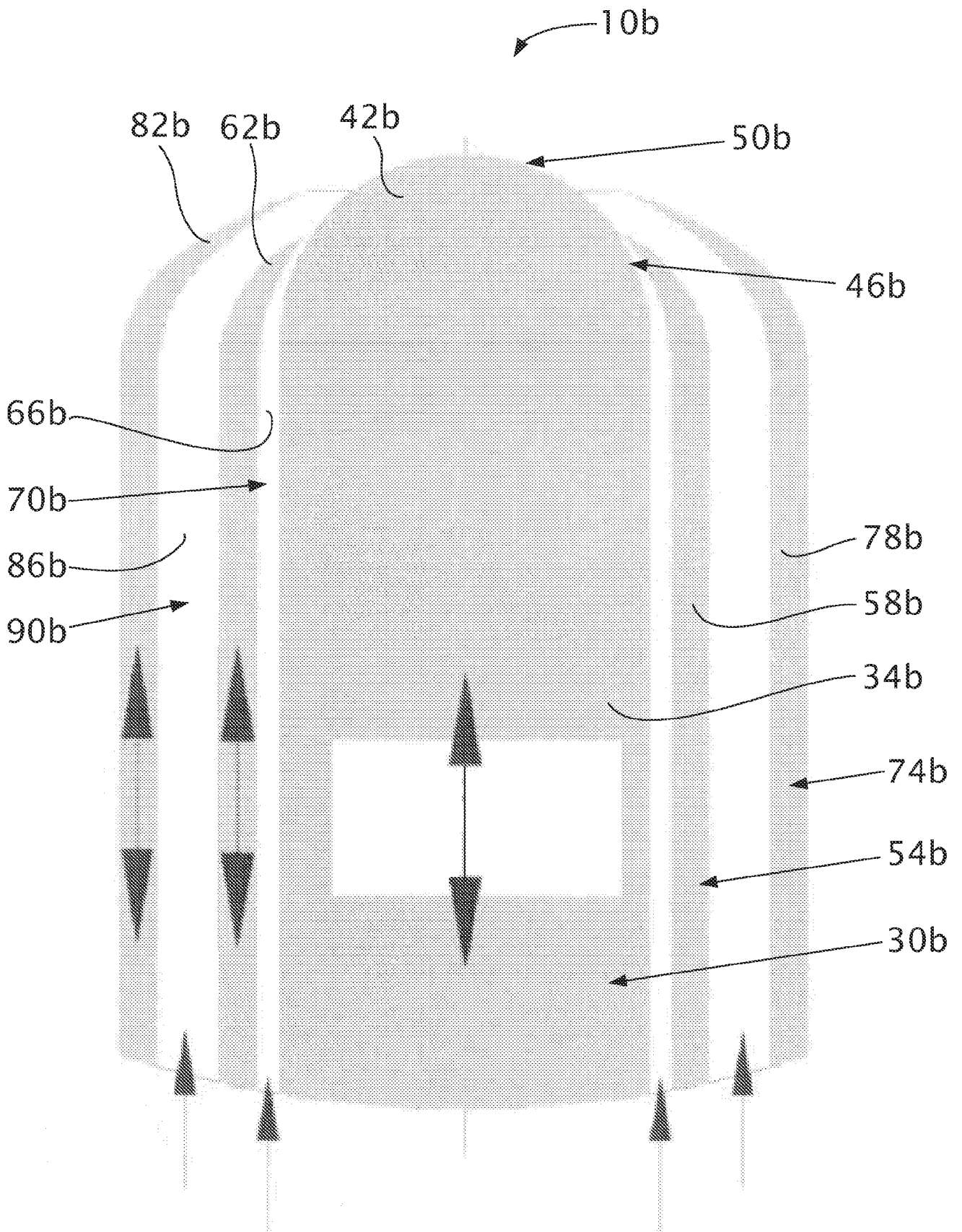

FIG. 3B

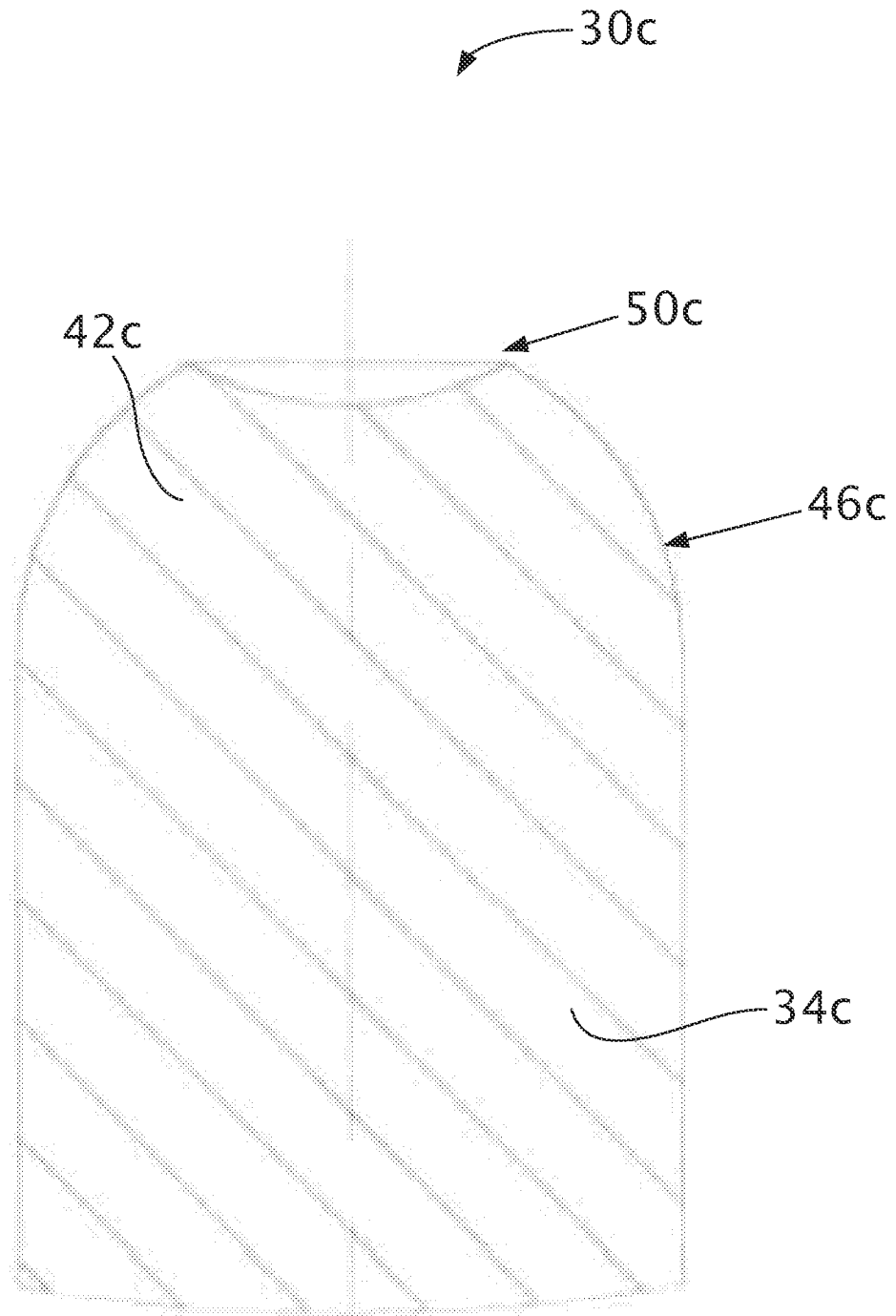

FIG. 4A

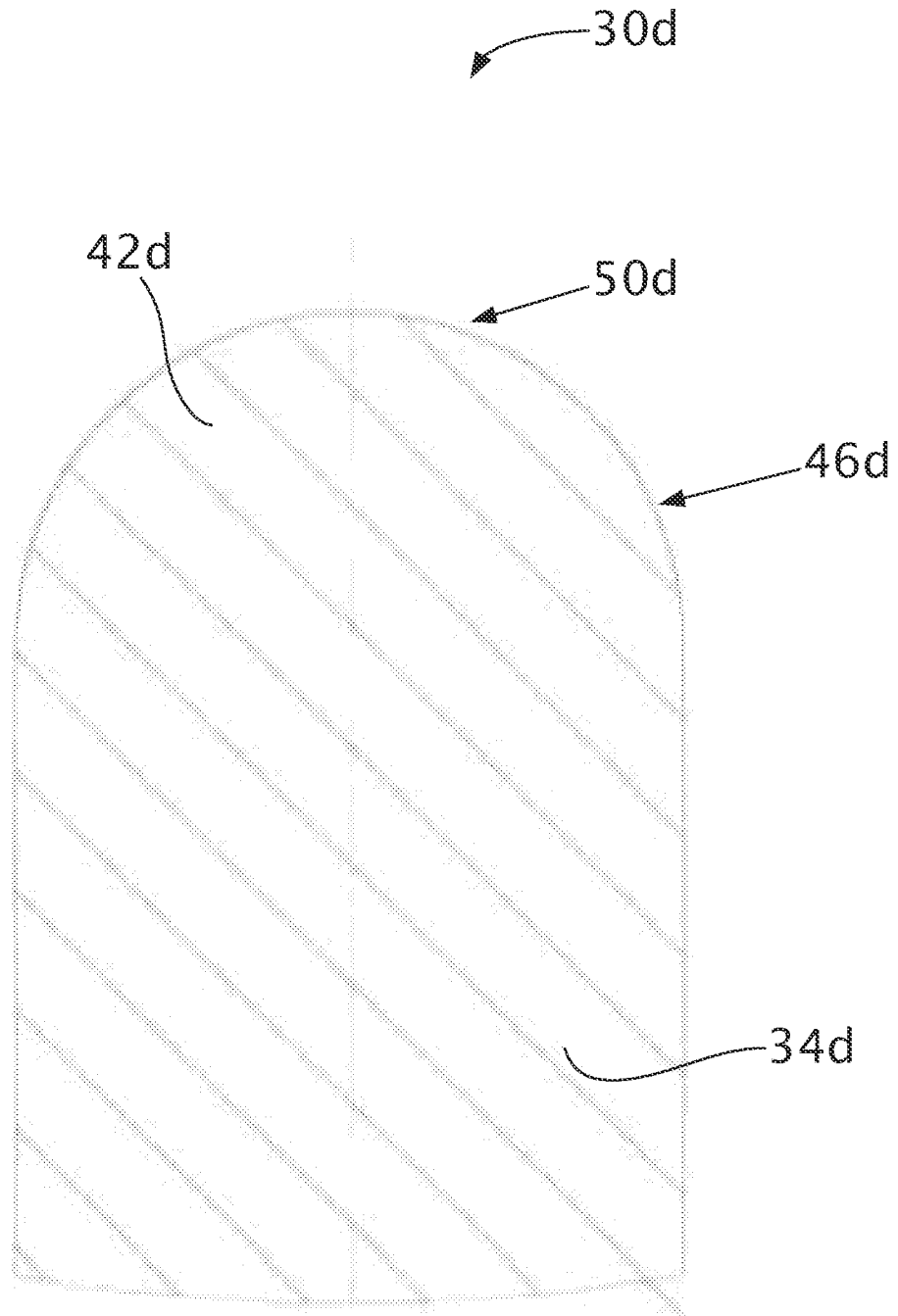

FIG. 4B

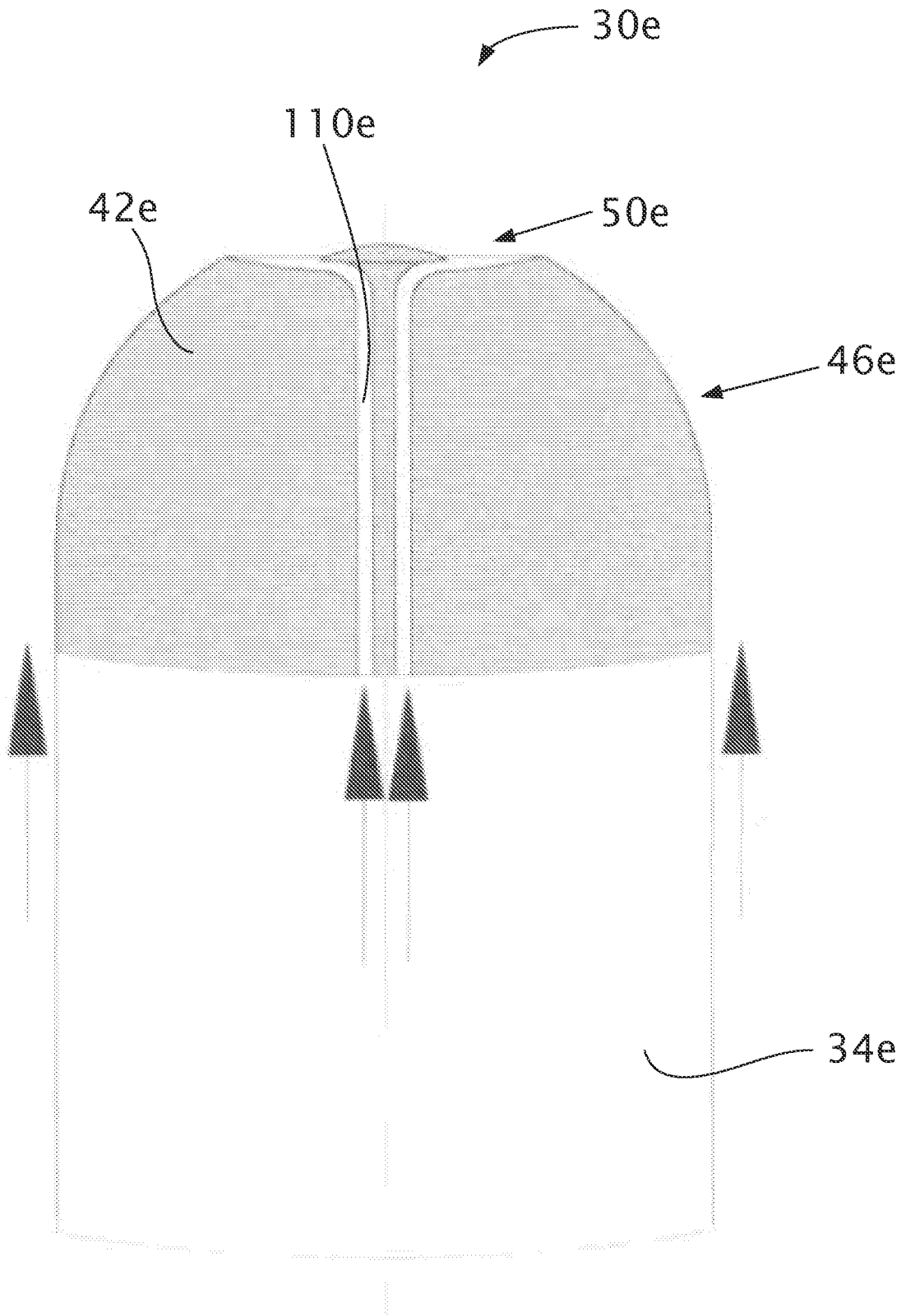

FIG. 4C

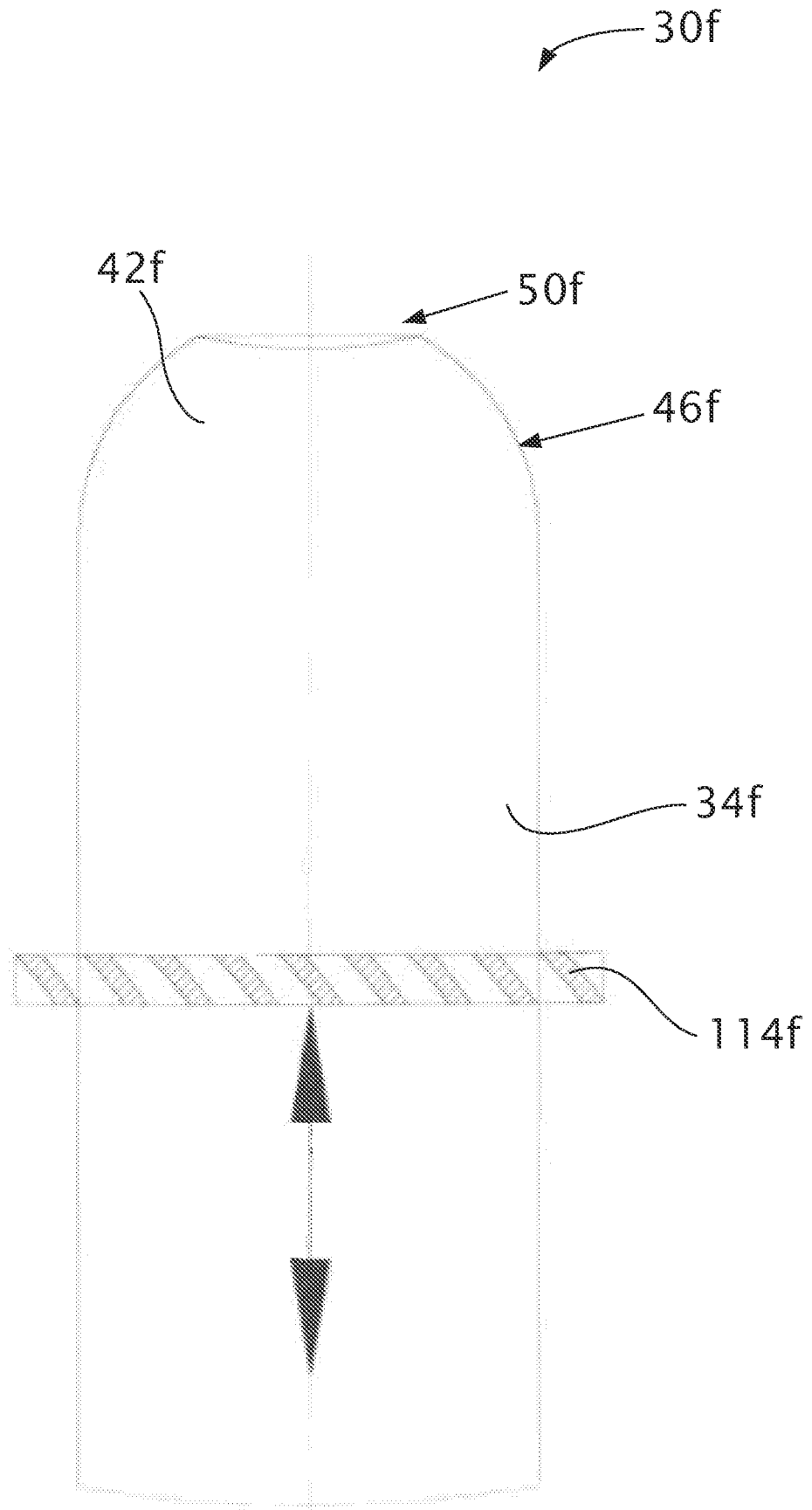

FIG. 4D

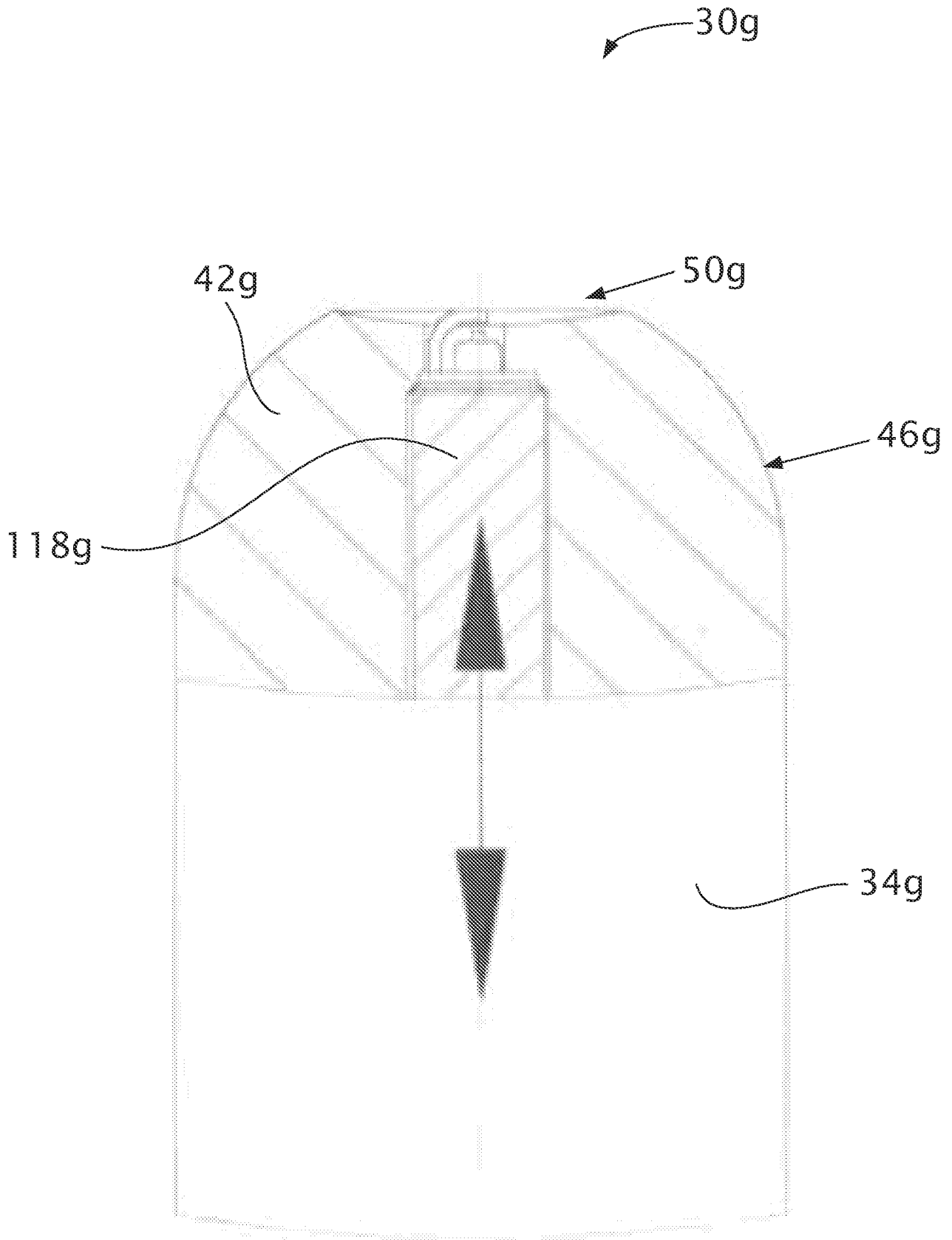

FIG. 4E

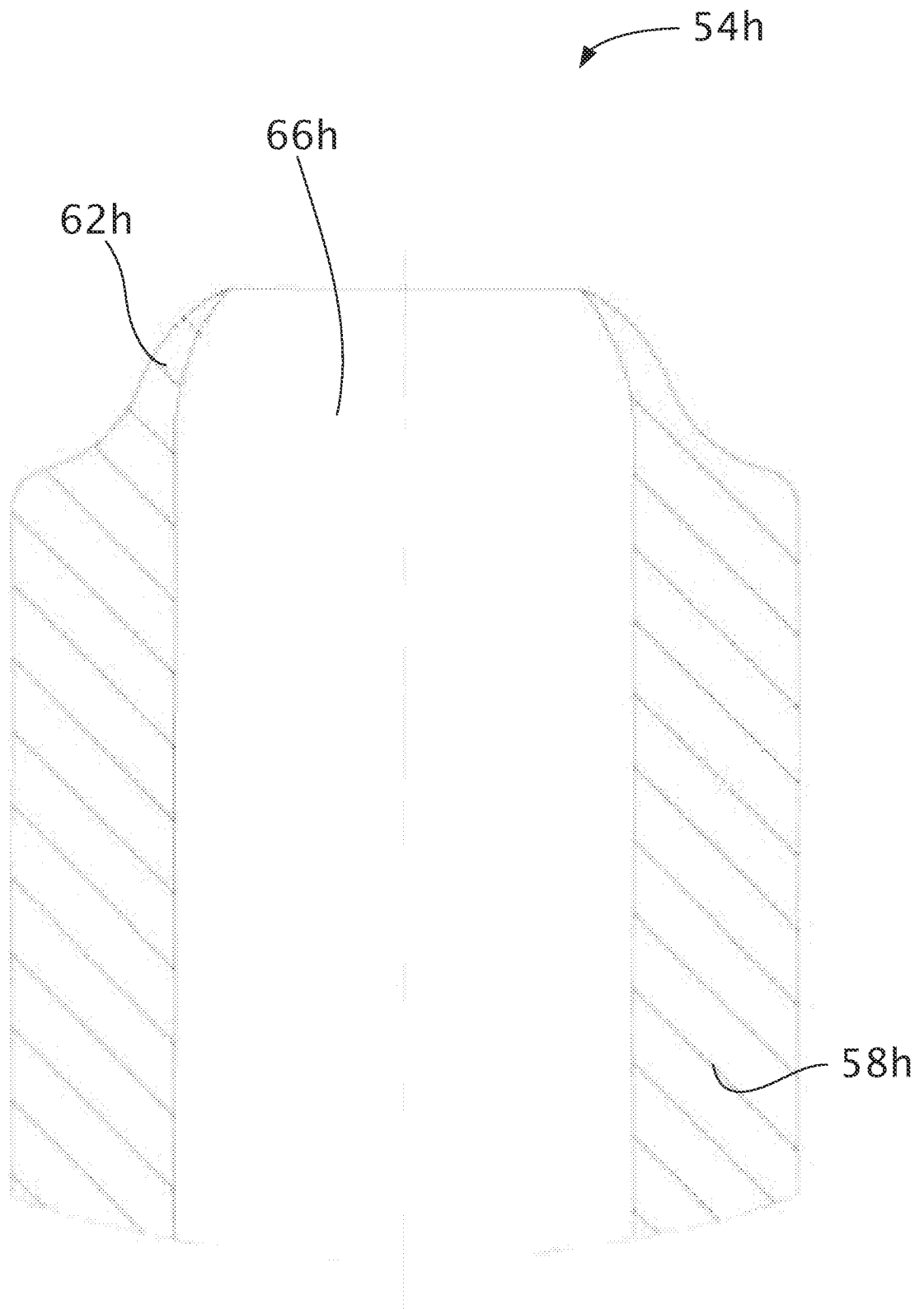

FIG. 5

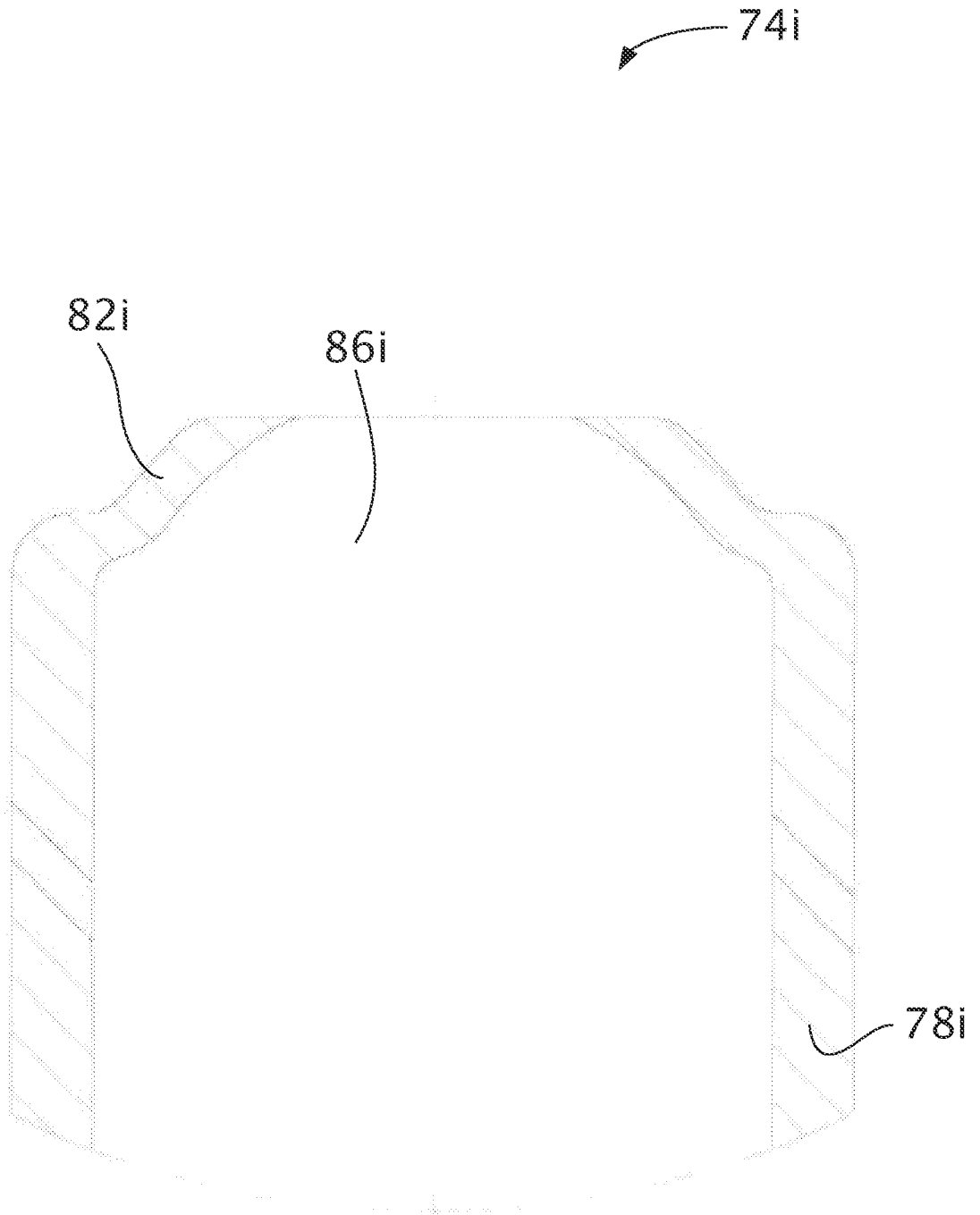

FIG. 6

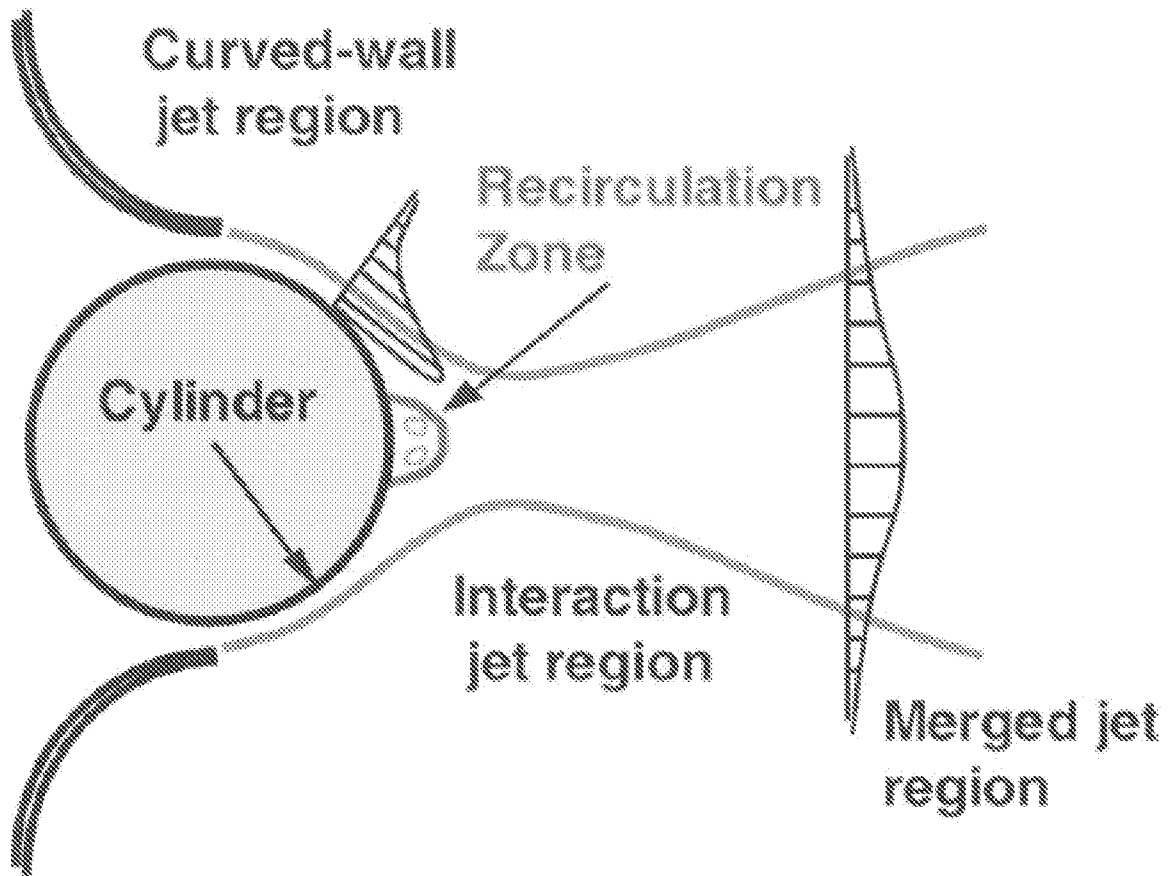
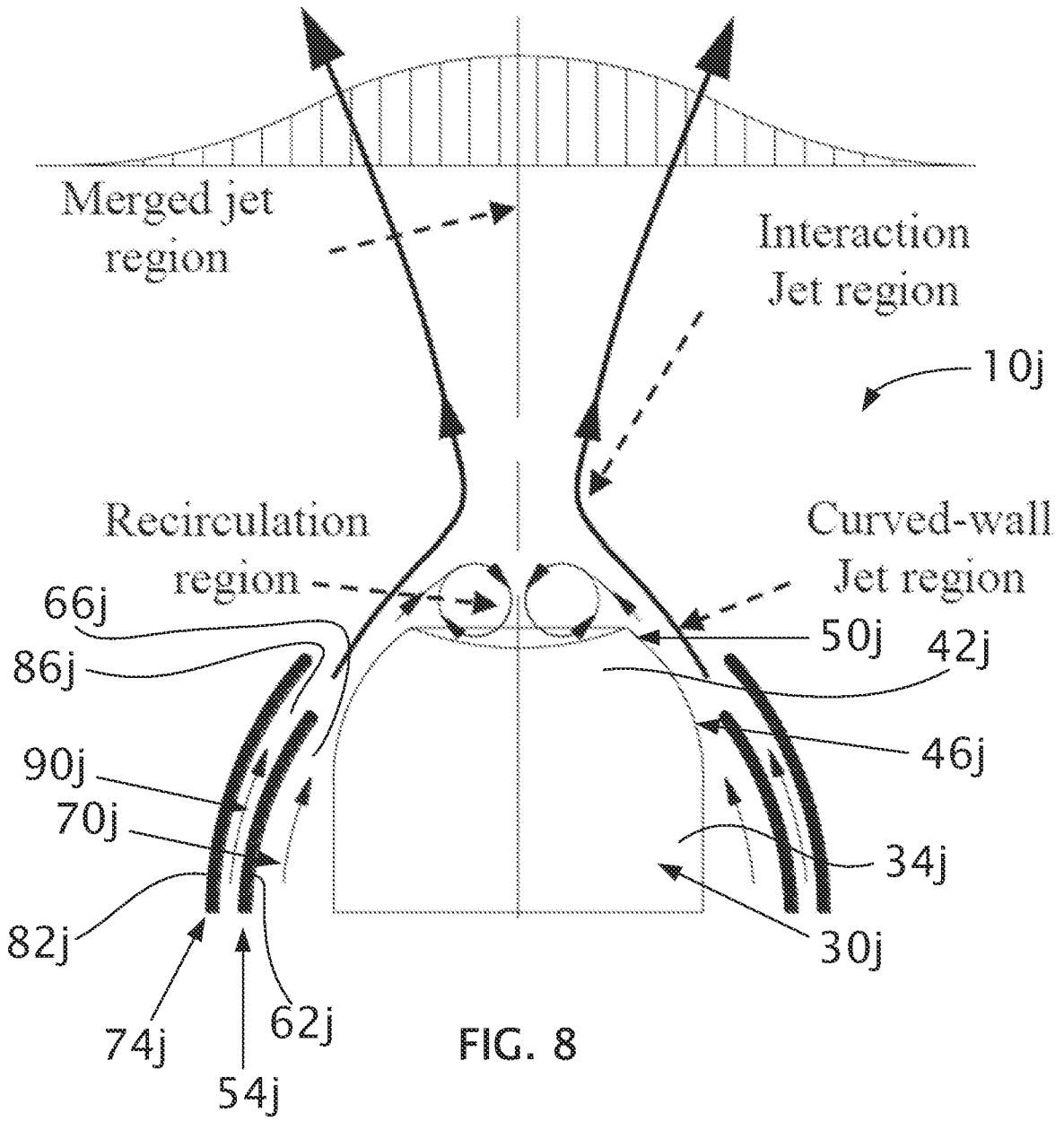

FIG. 7



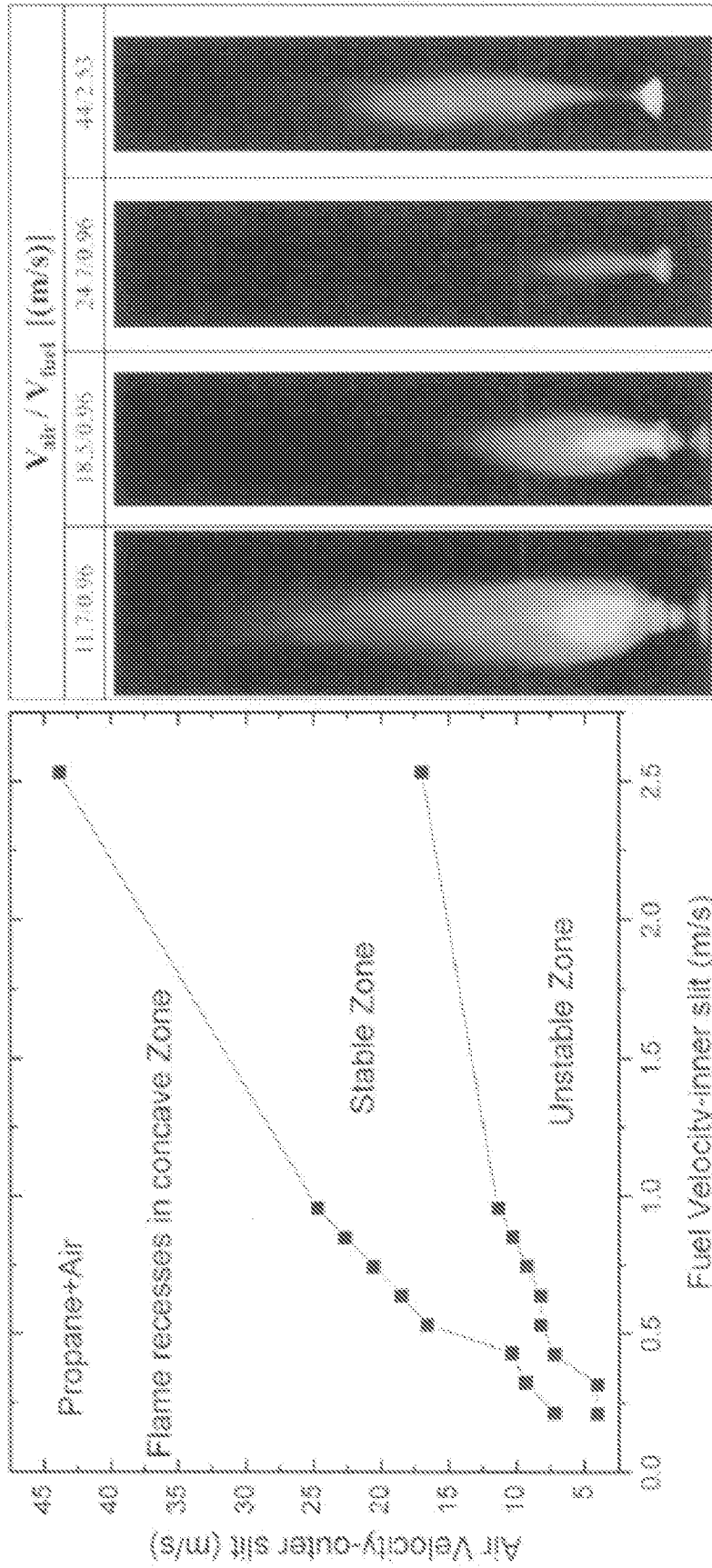

FIG. 9